

# Mx350i-T

## Automated Print & Apply Labelling Made Easy

With the **Mx-Series** we have simplified the process of printing and applying GS1-compliant labels, including traceability codes, on your products and packages. The **Mx350i-T** offers advanced connectivity options and the flexibility to switch between contact and non-contact applications. Ideal in industries requiring a robust all-around and easy-to-operate system, including food, beverage, and life sciences, as well as industrial, electronics etc.



### Easy to integrate

- ◆ With one of the smallest footprints on the market and left- and right-hand variants, you can easily fit your **Mx350i-T** print and apply solution into any production line.
- ◆ The **Mx350i-T's** advanced connectivity options allow for seamless integration with ERP, WMS, and MES systems in your factory.



### Easy to use

- ◆ The user-friendly integrated UI and optional remote 10-inch touchscreen make the **Mx350i-T** very easy to operate.
- ◆ The robust design and clever functionality minimises the time needed for media changes and maintenance, so you can maximise your production uptime.

### Easy to adapt

- ◆ The **Mx350i-T** is built to last, it will serve you for a long time and its flexibility ensures it can adapt to your evolving labelling needs without the need for costly investments.
- ◆ **Mx350i-T** is highly configurable and offers several options to further refine and simplify your labelling processes.

[www.domino-printing.com](http://www.domino-printing.com)



# A complete solution for all labelling needs



Our services are designed to provide operational insight so you can eliminate downtime and maximise production efficiency

## Operational support

Our extended warranty packages provide high-quality, on-site assistance and augmented reality-enabled remote guidance from our engineers. **SafeGuard** helps to ensure we can be with you when you need us most.

## Automatic code inspection

Ensure every code that leaves your factory is present and correct, and free up operator time. With **R-Series**, Domino's range of vision control systems, you can automate your code inspection to validate code presence, placement, and readability.

## Control software

Control your product codes from a central location and streamline product changeovers. Domino Automation uses standard communication protocols and can be integrated into existing ERP systems.

## High-quality consumables

Domino provides an extensive range of high-quality consumables for both general purpose and niche requirements. To achieve brilliant results and protect your printer, only use genuine Domino consumables.



## Technical specification **Mx350i-T**

Model	Mx350i-T4	Mx350i-T6
Print width	4-inch (108mm)	6-inch (162mm)
Print technology	Thermal transfer / Direct thermal	
Print resolution	12 dots/mm (300dpi)	
Printer variants	Left hand or Right hand	
Max print speed	400mm/s	250mm/s
Distance to product (D)	200mm model: 10-160mm 400mm model: 10-360mm 600mm model: 10-560mm	
Product motion	Moving or Stationary	
Apply method	Contact (tamp) or Contact-less (blow/tamp)	
Label position		
Recommended label width	25-110mm	25-150mm
Recommended label length	15-210mm	
Label & ribbon roll length	Up to 600m	
Input voltage	90-250VAC 50/60Hz	
Communication	4x Ethernet, TCP/IP, 2x USB-A, 1x USB-B	
I/Os (configurable)	12 inputs and 12 outputs	

### Dimensions

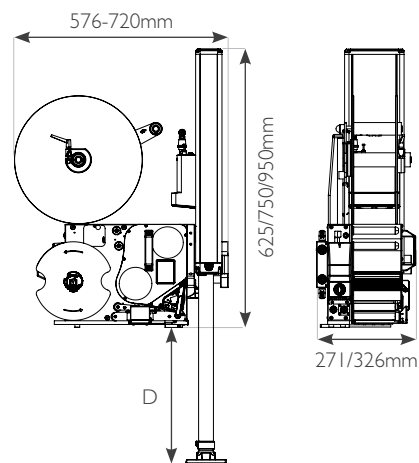

CONTACT US

## TALK TO AN EXPERT

- 800.444.4512
- solutions@domino-na.com
- www.domino-na.com/contact

