

J322 – Large Character Valvejet Printer

J322 is the latest large character printer for coding on woven bags, shipper boxes and metals.

The proven drop-on-demand Valvejet technology allows reliable coding and easy integration into manufacturing lines.

Its robust and reliable design ensure maximum performance in challenging manufacturing environments across different industries including cement, sugar, petrochemicals, fertilizers, and steel.



Flexible, Reliable & Robust

- ◆ **Sealed Electronics:** The electronics are sealed inside the printer enabling improved protection in challenging factory environments.
- ◆ **Sealed Printhead Nozzles:** The nozzles get sealed when the printer is not in use there by enabling higher uptime.
- ◆ **Flexibility:** Printheads can operate in different orientations viz. side and top. The high-performance ink enables excellent adhesion on wide range of porous and non-porous surfaces like paper bags, woven bags, metals, shipper boxes, and plastics etc.



Main Features :

- Ink replacement is quick and clean using the self-sealing connector without stopping the printer. The large 5 litre bag-in-box significantly reduces the ink replenishment frequency.
- Adjustable drop size helps in selecting most suitable drop size based on application enabling enhanced savings and sustainability
- 5.7" inch detachable touchpad user interface for message creation and setting up of printers.

Key Benefits :

- Reliable performance in harsh environments
- Excellent print quality and can be read from longer distances
- Fully electric - No factory air required
- Auto updatable variables - like counters, date, time etc.

www.domino-printing

Application Options

- Checkweigher interfacing module for printing real time weight
- Customized Message management through remote software for enabling message creation and assignment to printers based on Production & dispatch planning.
- Custom LED displays for real time print message and counter visibility at loading bay

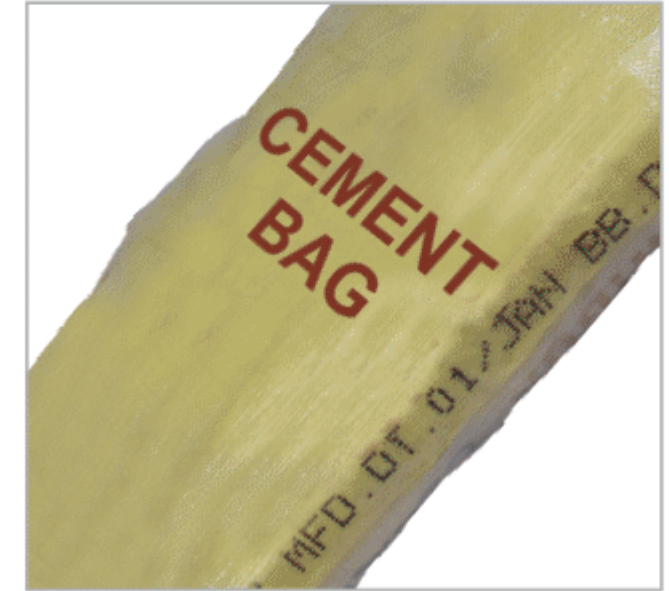
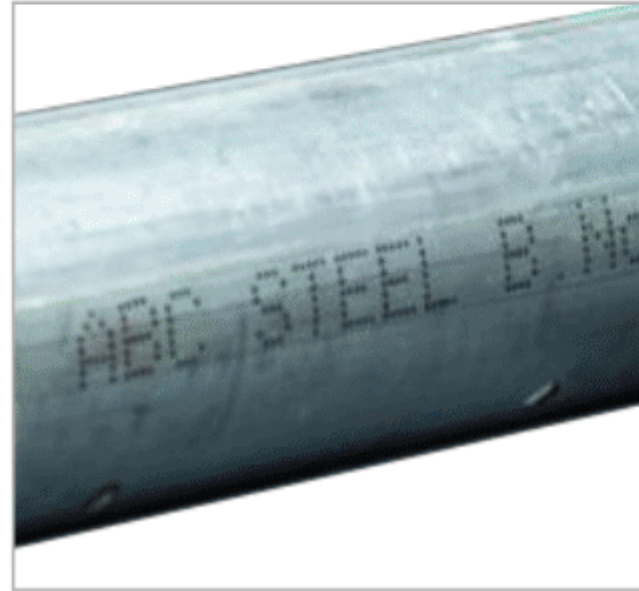

Technical specification

J322		J322A	J322B
Model		J322A	J322B
Dimensions		430mm (W) x 388.6mm (D) x 415mm (H)	
Weight		21 kg	22.3 Kg
Electrical Supply		Input 220 - 250VAC, 50Hz, 78VA Maximum	
Standard Connection		Product Detector, Shaft Encoder	
Optional Hardware Packs		GPIO Pack, Application Pack	
Print Head			
Dimensions		70mm (W) x 223mm (D) x 85mm (H)	70mm (W) x 269mm (D) x 111mm (H)
Printing Options		20mm Single line (7 X 5 matrix)	32mm Single line (16 X 10 matrix)
		16mm Single line (5 X 5 matrix)	14mm two lines (7 X 5 matrix)
		12mm single line (7 x 5 matrix) optional	10mm two lines (5 X 5 matrix)
Conduit length		4 Meters	
Touchpad			
User interface		5.7" full colour handheld touchscreen (640 x 480 resolution), 0.4 Kg, with docking station	
Dimensions		173mm (W) x 34mm (D) x 128mm (H)	
System Specification			
Operating Temperature		5-45 °C	
Operating relative humidity		10 - 90% RH (non-condensing)	
Enclosure		Stainless Steel 304	
Ink		Black, fast drying high performance industrial printing ink	

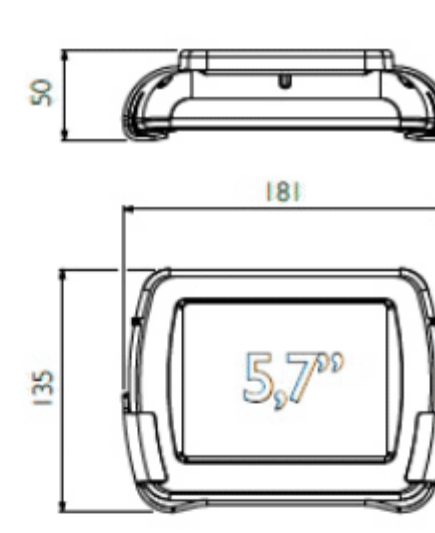
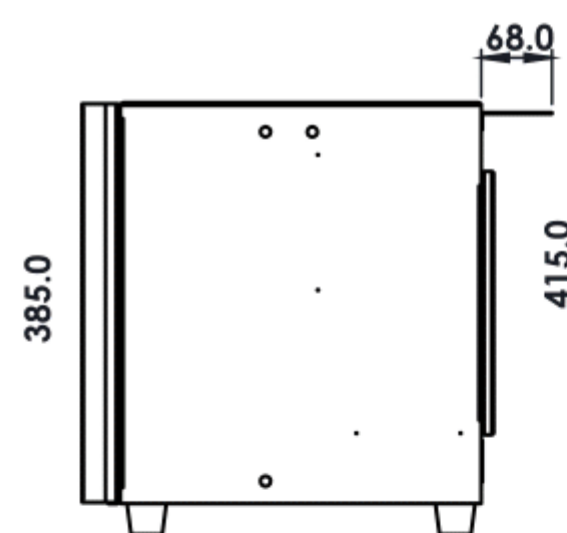
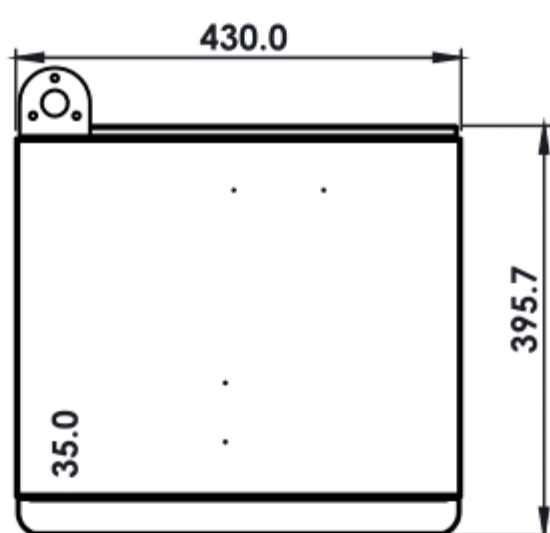

CONTACT US

TALK TO AN EXPERT

+91-900 900 6612
 enquiry@dominoindia.com
 www.domino-printing.com



KNOW MORE

Domino Printech India LLP, 117, Sector - 8, IMT Manesar, Gurugram, Haryana, India - 122050