



G-Series Product Manual

G50i

DOMINO

All rights reserved. No part of this publication may be reproduced, stored on a retrieval system, or transmitted in any form, or by any means, electronic, mechanical, photocopying, recording or otherwise, without the prior permission of Domino Printing Sciences plc.

Domino Printing Sciences plc. has a policy of continuous product improvement, the company therefore reserves the right to modify the specification contained in this document without notice.

© Domino Printing Sciences plc 2023.

For sales, service and inks please contact:

www.buydomino.com

www.domino-printing.com

Domino UK Limited

Trafalgar Way

Bar Hill

Cambridge CB23 8TU

United Kingdom

Tel: +44 (0)1954 782551

Fax: +44 (0)1954 782874

Email: enquiries@domino-uk.com

Domino North America

1290 Lakeside Drive

Gurnee IL.60031

U.S.A.

Tel: +1 847 244 2501

Fax: +1 847 244 1421

AMENDMENT RECORD

Amendment

All parts at Issue 1

All parts at Issue 2

Date

October 2022

August 2023

PREFACE PRODUCT MANUAL

This document, Domino Part No. EPT077343, is the official authority for the installation, operation, maintenance and recycling of Domino G-Series Thermal Ink Jet units.

This document should be used to reinforce and complement any training program available with the product. It is not designed to replace any such training program.

This product manual is the source document for all translated versions. It is the "Original Instructions".

Domino will not accept any liability for damage to equipment or injury to personnel caused by unauthorized or improper use of the Thermal Ink Jet equipment.

Only engineers trained by Domino should carry out repairs, adjustments or in any other way alter settings or machine parts. Domino original parts shall always be used to ensure quality and performance.

Users of this equipment are warned that it is essential to read, understand and act according to the information given in Part 1: Health and Safety. This part of the document also specifies a set of symbols which are used elsewhere in the document to convey special warnings or requirements. It is, therefore, essential that users are also familiar with these symbols and act accordingly.

It is important to:

- Keep this document during the lifetime of the equipment.
- Pass this document on to any subsequent holder or user of the equipment.

FCC NOTICE

This equipment has been tested and found to comply with the limits for a Class A digital device, pursuant to part 15 of the FCC Rules. These limits are designed to provide reasonable protection against harmful interference when the equipment is operated in a commercial environment. This equipment generates, uses, and can radiate radio frequency energy and, if not installed and used in accordance with the instruction manual, may cause harmful interference to radio communications. Operation of this equipment in a residential area is likely to cause harmful interference in which case the user will be required to correct the interference at his own expense.

Any changes or modifications not expressly approved by the manufacturer could void the user's authority to operate the equipment.

EUROPEAN EMC STATEMENT

This product may cause interference if used in residential areas. Such use must be avoided unless the user takes special measures to reduce electromagnetic emissions to prevent interference to the reception of radio and television broadcasts.

INTENDED USE

The device described in this document is an industrial printer designed to be used indoors in a professional environment for printing onto a variety of substrates and products. Do not use for any other purpose unless authorised by Domino. If the equipment is used in a manner not specified by Domino, the protection provided by the equipment may be impaired.

SOFTWARE CREDITS

Barcode Engine by TEC-IT - www.tec-it.com

This product uses the following libraries. The libraries and their use are covered by the GNU Lesser General Public License, version 2.1.

Backend			
GNU C Library	2.28-10	Libevent	2.1.8
Libusb	1.0.22-2	Libxml2	2.9.4
Libhiredis	1.0.2	Libpixman	0.36.0
Redis	5.0.5	Libpangocairo	1.42.4-8
Chromium	88.0.4324.187	Librsvg	2.44.10-2
Libcairo	1.16.0-4	Libicu	63.1-6
Libpango	1.42.4-8	gir1.2-glib-2.0	1.58.3-2
Libpng	1.6.36-6	Libcsvg	1.0
Libjpeg	1.5.2-2	Libbcm2835	1.69
Libtiff	4.1.0	Zip	3.0-11
Libfontconfig	2.13.1-2	Unzip	6.0-23
Libfreetype	2.9.1-3	feh	3.1.3-1
Libjson-c	0.12.1	Libthai	0.1.28-2
libgdk-pixbug2.0	2.38.1	libgudev	232.2
libglib2.0	2.58.3-2	libcroco3	0.6.12-3
UI			
Nodejs	14.17.1		
Redis	3.1.2		
Socket.io	2.4.1		
express	4.17.1		
multer	1.4.2		
express-sessions	1.7.2		
compression	1.7.4		
Fabricjs	4.6.0		

CONTENTS

	page
- Domino.....	2
Amendment Record.....	2
Preface Product Manual.....	3
FCC Notice.....	4
European EMC Statement.....	4
Intended Use.....	4
Software Credits.....	5
PART 1 - HEALTH AND SAFETY.....	10
Introduction.....	10
Warnings, cautions and notes.....	11
Symbols.....	11
Inks and Fluids Information.....	13
Storage.....	13
Fire Risk.....	14
Spillages and Disposal.....	14
Electro-Static Discharge.....	15
Product/Battery End of Life.....	16
USA State of California Battery Statement.....	16
PART 2 - SYSTEM DESCRIPTION.....	17
Introduction.....	17
General.....	17
Description.....	17
Overview.....	18
G50i Controller Overview.....	18
GP Printhead Overview.....	20
EXT Printhead Overview.....	21
User Interface.....	22
Specification.....	23
Controller Specification.....	23
GP Printhead Specification.....	24

GP Printhead Speed Table.	25
EXT Printhead Specification.	26
EXT Printhead Speed Table.	27
Pre-installed Fonts.	28
Controller IO Socket Description.	29
Maximum Label Width.	31
User Interface Overview.	32
Main Interface Tool Bar.	32
Home Screen Print Information.	35
Label Template Designer.	38
PART 3 - INSTALLATION.	41
Unpacking.	41
Location.	41
Vertical Installation.	42
Horizontal Installation.	46
Anti Shock (Optional) Installation.	50
Printhead Orientation.	51
Side View.	51
Front View.	52
Printhead Connection.	53
Ink Cartridge Installation.	54
Controller Electrical Supply.	56
Printhead Product Detect Sensor Calibration.	58
External Device Connection.	59
External Product Detect Sensor.	59
External Shaft Encoder.	61
Alarm Beacon.	62
IO Connection.	63
Printhead Settings.	64
Print Quality.	64
Alignment.	65
System Settings.	66
Encoder Input - Internal.	66
Encoder Input - External.	67
Print Trigger - Continuous.	68
Print Trigger - Sensor.	69
Bi-Direction.	70

Auto Switch Channel.	71
High Speed.	71
Print Static Image.	72
Skew Angle.	72
Auto Jet (Nozzle Purge).	73
Realtime.	74
Advanced Settings.	75
Display.	75
User Mode (Security).	76
Remote.	81
High Quality.	82
IO Signal.	83
Backup and Restore.	84
Common.	85
Configuring Print Controls.	86
VDC Settings.	87
VDC (Variable Data Connection).	87
Rule.	90
Monitor.	93
Network Settings.	94
IP Address.	94
DNS Server Address.	95
Control the Printer via Web Browser.	96
Power Save Settings.	97
Monitor.	97
Language Settings.	98
Import Language.	98
Export Language.	99
Delete Language.	99
Font Settings.	100
Import Font.	100
Delete Font.	100
PART 4 - OPERATION.	101
Start Up.	101
Load a Label to Print.	104
Start Printing.	105
Stop Printing.	105
Shut Down.	106
Design a Label Template.	108

Add Objects to Label Template.....	109
Add a Text Object.....	109
Add a Counter Object.....	111
Add a Database Object.....	114
Add a Barcode Object.....	125
Add a Static Graphics Object.....	128
Add a Dynamic Graphics Object.....	130
Add a Clocks Object.....	139
Add a Shift Code Object.....	144
Add a Line Object.....	146
Add a Boxlot Object.....	147
Save Label Template.....	150
Save Label Template with Different Name.....	150
Edit Object Properties.....	151
Delete Label Template.....	151
Import Label Template.....	152
Export Label Template.....	153
Log.....	154
Export Log.....	155
Statistic Counters.....	156
PART 5 - MAINTENANCE & TROUBLESHOOTING.....	157
Error Description.....	157
Print Quality Faults.....	158
Update Software/Firmware.....	159
Replace Ink Cartridge.....	160
Purge Blocked Cartridge Nozzles.....	163
Clean the Cartridge Nozzles.....	164
Clean the Printhead.....	167
Clean the Controller.....	170

PART 1 HEALTH AND SAFETY

INTRODUCTION



If the equipment is used in a manner not specified by the manufacturer, the protection provided by the equipment may be impaired.

Directions for safe working practices vary according to the environment. The following are broad principles so that necessary precautions can be taken:

- Do not operate a the printer outdoors or in an environment outside of the specified operating range. This product is for indoor use only.
- Only use the electrical power supply adapter listed below:
 - Manufacturer: MEAN WELL ENTERPRISES CO. LTD
 - Model: GST60A24
- Do not install or operate the printer in an environment where it can be exposed to water.
- Avoid using and storing the printer in high dust environments.
- Read the Safety Data Sheet (SDS) before storing, handling, transporting or using the ink cartridges.
- Protect the printer from electrical surges or low voltage conditions by using a UPS (Uninterruptible Power Source).
- Turn off and disconnect electrical power to the printer before making any wiring connections.
- Turn off and disconnect electrical power to the printer before connecting or disconnecting a printhead.
- Make sure all cables are secured away from moving production line components.
- Stop printing before removing and/or installing an ink cartridge.
- Use only lint-free wipes when cleaning the cartridge nozzles.
- Clean cartridge nozzles according to the enclosed recommendations.
- Protect the printheads from impact with proper adjustment and alignment of side rails and product guides.
- Do not open any enclosed components. They contain no user-serviceable parts.
- Only use accessories that are approved by the manufacturer.
- Dispose of batteries, electrical and electronic products separately at an appropriate collection point. Do not put batteries, electrical and electronic products in the normal domestic waste stream.

WARNINGS, CAUTIONS AND NOTES

The warnings, cautions and notes used throughout this manual are highlighted by the use of international hazard symbols. The following definitions for all three of these notices are described below in the format they are presented in this document.

WARNING	What is the hazard. Risk of personal injury.
	A warning is used to alert the reader of hazards which may cause loss of life, physical injury or ill health.
CAUTION	Possible hazard. Risk of damage to equipment.
	A caution is used to alert the reader of possible hazards which may cause damage to equipment or the environment.

A note is used to alert the reader to important information.

Symbols

The following symbols are used in this document to highlight specific warnings and cautions used in the procedure below the symbols.



Warning or Caution, read and comply with the warning or caution text to avoid physical injury, damage to equipment or damage to the environment.



Risk of fire by igniting flammable material.



Risk of coming into contact with electricity.



Beware of Electrostatic Discharge (ESD). Electrostatic precautions must be used:

- Switch off the machine.
- Wear a wristband connected to ground.
- Avoid wearing clothing that can build up electrostatic voltages.
- Use ESD protective bags to transport PCBs.
- Only place PCBs on a mat made from a material which will dissipate electrostatic voltages and which is connected to ground.



Eye protection must be worn.



Protective clothing must be worn. Use adequate protective gloves. Consult the relevant Safety Data Sheet (SDS).

HEALTH AND SAFETY



Disconnect power before carrying out maintenance or repair.



Connect an earth terminal from the product to an appropriate ground source.



Read the manual before doing this procedure.

INKS AND FLUIDS INFORMATION

Domino supplies Safety Data Sheets (SDS) giving specific safety information for each of its inks. Safety Data Sheets can be found on the MSDS section of the Domino website.

When used correctly, printing inks do not cause problems. However, everybody using them should be familiar with the appropriate safety standards and be aware of the precautions that should be taken. The following are basic requirements:

- Proper standards of industrial practice relating to cleanliness and tidiness must be maintained.
- Inks and their containers must be stored and handled with care.
- Do not smoke or allow naked flames (or other sources of ignition) in the vicinity of any inks or solvents as this is highly dangerous.
- All who come into contact with inks must be properly instructed in their use.
- Contact with the mouth must be avoided. Therefore eating, drinking or smoking, or any personal habits or actions which may transfer ink to the mouth must be avoided.
- Contact with the eyes must be avoided. Suitable eye protection must always be worn whenever there is any risk of splashing or misting. If ink does get into the eyes, first aid treatment is to flood the affected eye for 15 minutes with saline solution, (or clean water if saline solution is not available), taking care not to allow the water to run into an unaffected eye. Medical aid must be obtained immediately.
- Most inks contain solvents that may injure the skin. Good working practice must always be employed and risk assessments carried out. Safety Data Sheets are available that give advice on personal protective equipment. Most gloves offer limited and short term exposure protection and must be changed after any splashing and on a frequent basis.
- Many inks contain materials which vaporise easily and can be inhaled. Good ventilation is necessary.
- Any used cleaning materials, e.g. rags, paper wipes, are a potential fire hazard. They must be collected for safe disposal after use. After exposure to ink, all possible traces must be washed off as soon as possible at the nearest washing facility.

Storage

Printing inks must be stored in well-ventilated buildings, in areas set aside for the purpose and chosen for safety in case of fire. All fluids must be stored in accordance with local regulations.

Fire Risk

Observe all warnings given on the machine and the following safety instructions.

For an electrical fire, do not use water.

If there has been an accumulation of dried ink, do not use metal scrapers to remove it, as they can produce sparks.

Fire risk is a most important consideration where printing inks are stored and used. The degree of fire hazard will vary considerably from one type of ink or wash to another.

Water-based inks will not burn, although inks based on water-alcohol mixtures may burn if there is sufficient alcohol present.

Prolonged exposure of water-based systems to high temperatures may evaporate the water to give a flammable residue.

Solvent-based inks offer a greater degree of hazard depending on the particular solvent or solvent combination. When there is a particular hazard the appropriate information is given on the SDS.

If there is a fire, there is a likelihood that dangerous fumes will arise from printing inks. For this reason, ink must be stored where it can be reached quickly by the fire fighting service, and where it will not spread beyond the store.

Spillages and Disposal

WARNING		Flammable material. Risk of fire.
		<p>Do not allow ink to dry or allow any build-up of dried ink.</p> <p>Some dried inks are highly flammable. Clean up all ink spillages immediately.</p>

Spillages must be cleaned up as soon as possible with the appropriate solvent materials and with regard to the safety of personnel. Care must be taken to prevent spillages or residue from cleaning up entering drains or sewage systems.



Inks and associated fluids are materials that conduct electricity. Therefore, the power to the printer must be switched off while spillages are being cleaned up.

Printing inks and associated fluids must not be treated as ordinary waste. They must be disposed of using approved methods according to local regulations.

ELECTRO-STATIC DISCHARGE

To avoid static discharge from production line equipment, the equipment and everything on it must be grounded correctly. While it is not Domino's responsibility to maintain the customer's equipment, the customer must be aware of the importance of grounding. At the time of installation of the printer, the Domino (or Domino distributor) technician should ensure that the line the printer is installed on is appropriately grounded. This means that all metallic items within 12 inches (300mm) of the printhead location must be securely grounded. This should be checked with respect to the printhead chassis ground using an Ohm Meter, DVM or another suitable device. It is essential that grounding is checked periodically and that if the printer is relocated to a different production line, then the new production line is properly grounded. Additional static dissipating devices, such as static brushes on the line, etc. are recommended.

PRODUCT/BATTERY END OF LIFE

WARNING		Flammable material. Risk of fire or explosion.
	Do not dispose of the battery in a fire, hot oven, by mechanically crushing or cutting. Obey local waste regulations when disposing of batteries.	
	Do not store or leave the battery in high or low extremes of temperature.	
	Do not store or leave the battery in a location that is subject to low air pressure at high altitudes.	
CAUTION		Hazardous Material. Risk of damage to equipment and environment.
	The battery is not removable. If the battery needs replacement, replace the PCB that the battery is installed on. Obey local waste regulations when disposing of the battery and PCB.	

Recycling information in accordance with the WEEE and Battery Directives



Product Mark



Battery Mark

European Union Only

The product/battery is marked with one of the above recycling symbols. It indicates that at the end of life the product/battery, you should dispose of it separately at an appropriate collection point and not place it in the normal domestic waste stream.

USA STATE OF CALIFORNIA BATTERY STATEMENT

Perchlorate Material - special handling may apply.

See www.dtsc.ca.gov/hazardouswaste/perchlorate

PART 2 SYSTEM DESCRIPTION

INTRODUCTION

General

This document provides:

- A basic introduction of the Domino G-Series.
- Details of the user interface.
- Instruction for label creation.
- Preventative maintenance procedures.
- Fault finding and diagnosis.
- Details on updating the software.

Description

The Domino G-Series is a range of thermal ink jet printers intended for printing fixed and variable data on products on manufacturing production lines. For specific details, contact your local support office.

Each G50i consists of:

- 1 printhead with a cable connecting the printhead to a controller.
- A controller containing the electronic control systems.

OVERVIEW

G50i Controller Overview

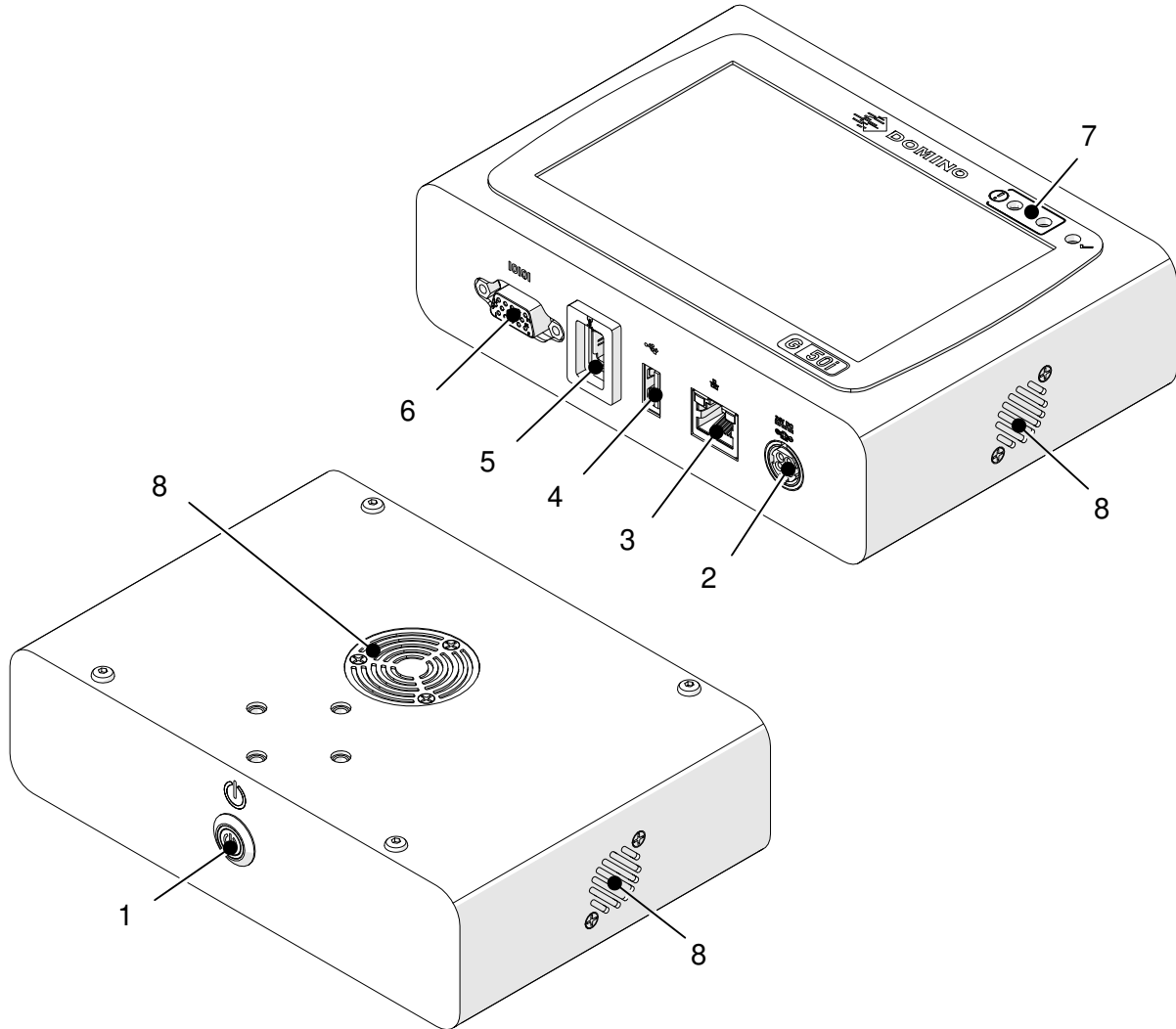

#	Name	Description
1	Standby button	<p>Note This button does not disconnect/ connect electrical power.</p> <p>Either:</p> <ul style="list-style-type: none"> • Press to boot up the printer • Press and hold for 2 seconds, to shut down the printer.
2	Electrical power supply input	24 V DC, 2.5 A
3	Ethernet Socket	Connect the printer to a network or PC for data transfer.

SYSTEM DESCRIPTION

#	Name	Description
4	USB Socket	Connect: <ul style="list-style-type: none"> • Keyboard • Mouse • Memory device for data transfer.
5	Printhead Socket	Connect the printhead.
6	IO Socket	Connect: <ul style="list-style-type: none"> • External sensor (product detect sensor) • External encoder (shaft encoder) • Alarm beacon.
7	Status LED	Status: <ul style="list-style-type: none"> • Stop (Red) - Turns on if the electrical power supply is connected and the controller has booted up. • Alarm (Amber) - Turns on if there is an error. • Run (Green) - Turns on when printing.
8	Fan	Cooling for the controller. Do not block the fan vents.

GP Printhead Overview

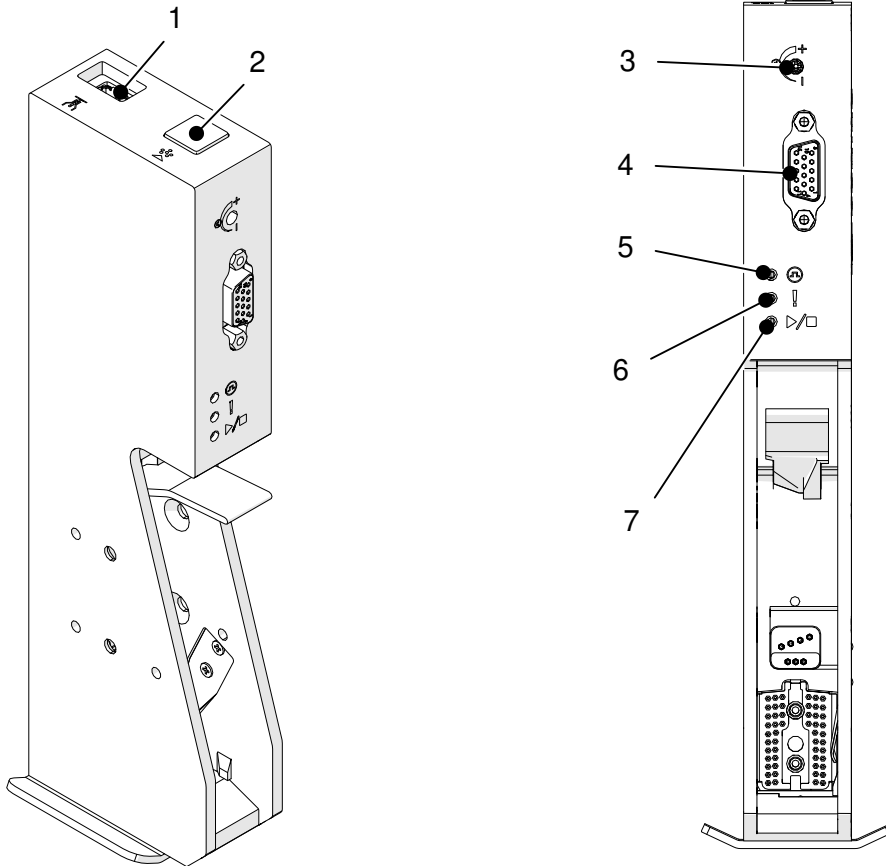

#	Name	Description
1	Data Socket	Connect the printhead to the controller.
2	Purge Button	Press to purge the printhead nozzles.
3	Sensitivity	Adjust the product detect sensor sensitivity.
4	Extended Socket	Do not use.
5	Sensor LED	Turns on when the product detect sensor is triggered.
6	Alarm LED	Turns on if there is an error.
7	Run/Stop LED	Turns on when printing.

EXT Printhead Overview

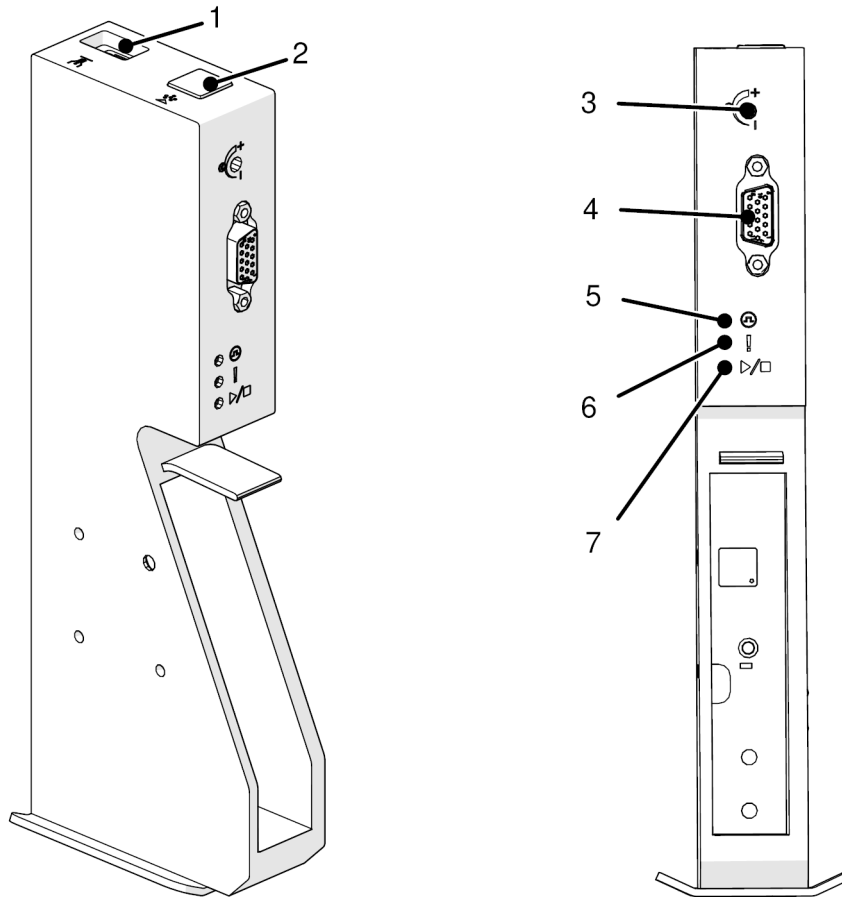

#	Name	Description
1	Data Socket	Connect the printhead to the controller.
2	Purge Button	Press to purge the printhead nozzles.
3	Sensitivity	Adjust the product detect sensor sensitivity.
4	Extended Socket	Do not use.
5	Sensor LED	Turns on when the product detect sensor is triggered.
6	Alarm LED	Turns on if there is an error.
7	Run/Stop LED	Turns on when printing.

User Interface

The 5 Inch touch screen on the controller displays the user interface. Setup, configuration, and label creation/editing are done directly on the touch screen (no external software required).

However, the printer can also be controlled using the web browser of a PC, laptop, or mobile device (smart phone), see [Control the Printer via Web Browser on page 96](#).

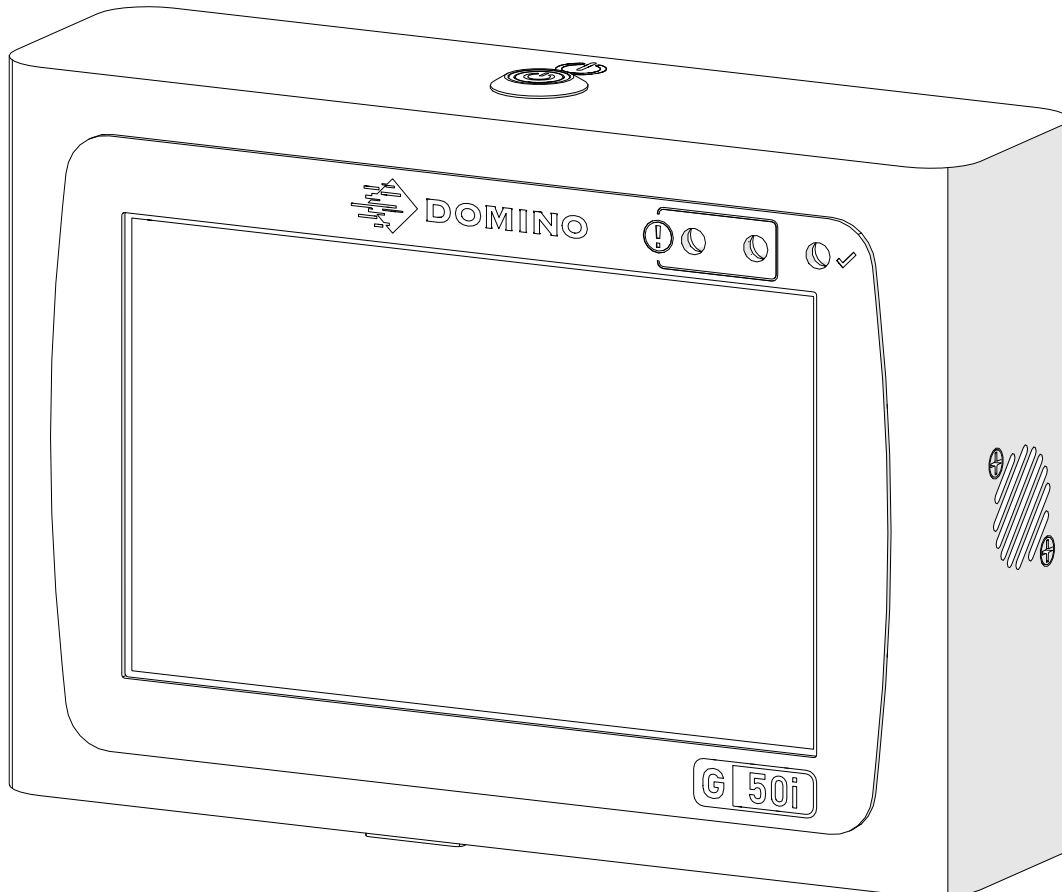

SPECIFICATION

Controller Specification

Item	Details
Dimensions:	Width: 155 mm Height: 111.6 mm Depth: 44.65 mm
Weight:	622 g
Operating Temperature:	5 °C to 50 °C
Operating Relative Humidity:	90% non condensing.
IP Rating	N/A (Not usable in wet locations)
User Interface:	5 Inch Touch Screen
Message Memory:	4 GB
Maximum Number of Printheads:	1
Printable Characters:	Windows True Type Fonts
Electrical Power Supply Adapter:	Input: 100-240 V AC, 1.4 A, 50/60 Hz Output: 24 V DC, 2.5 A, 60 W
Maximum Electrical Power Consumption:	60 W
External Connections:	<ul style="list-style-type: none"> • External Sensor (Product Detect Sensor) • External Encoder (Shaft Encoder) • Alarm Beacon • RS485 • RJ45 (Ethernet) • USB
Maximum Altitude of Operation:	2000 m
Intended Environment:	Indoors only

GP Printhead Specification

Item	Details
Maximum Print Height:	12.7 mm (0.5 Inch)
Dimensions:	Height: 65.1 mm Width: 49.1 mm Length: 216.4 mm
Weight:	412.4 g
Operating Temperature:	Note Check the specification of the ink type. 5 °C to 50 °C
Operating Relative Humidity:	90% non condensing.
IP Rating	N/A (Not usable in wet locations)
Printhead Cable Length:	2 m
Maximum Altitude of Operation:	2000 m
Intended Environment:	Indoors only

GP Printhead Speed Table

Note Print speeds depend on the ink type, resolution and application. Check the data sheet of the ink type.

Resolution	Density 1 Speed (m/min)
150x100	228
150x120	190
150x150	152
150x200	114
150x300	76
150x600	38
300x100	228
300x120	190
300x150	152
300x200	114
300x300	76
300x600	38
600x100	228
600x120	190
600x150	152
600x200	114
600x300	76
600x600	38

EXT Printhead Specification

Item	Details
Maximum Print Height:	25.4 mm (1 Inch)
Dimensions:	Height: 77.5 mm Width: 49 mm Length: 217 mm
Weight:	432 g
Operating Temperature:	Note Check the specification of the ink type. 5 °C to 50 °C
Operating Relative Humidity:	90% non condensing.
IP Rating	N/A (Not usable in wet locations)
Printhead Cable Length:	2 m
Maximum Altitude of Operation:	2000 m
Intended Environment:	Indoors only

EXT Printhead Speed Table

Note Print speeds depend on the ink type, resolution and application. Check the data sheet of the ink type.

Resolution	Density 1 Speed (m/min)
300x100	120
300x120	100
300x150	80
300x200	60
300x300	40
300x600	20

Pre-installed Fonts

Pre-installed fonts include:

- Liberation Mono (Regular/Bold/Italic/Bold Italic)
- Liberation Sans (Regular/Bold/Italic/Bold Italic)
- Liberation Sans Narrow (Regular/Bold/Italic/Bold Italic)
- Noto Sans (Regular/Bold/Italic/Bold Italic)
- Noto Sans Arabic (Regular/Bold)
- Noto Sans Hebrew (Regular/Bold)
- Noto Sans JP (Regular/Bold)
- Noto Sans KR (Regular/Bold)
- Noto Sans TC (Regular/Bold)
- Noto Sans Thai (Regular/Bold).

Controller IO Socket Description

Socket type: Female, 15-Way. High Density, D Connector.

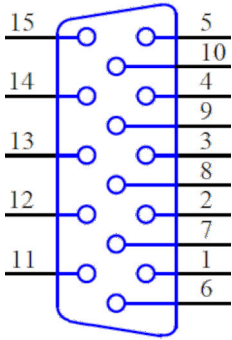

#	Name	Type	Description
1	485B	Communication	RS485B, inverting driver output/ receiver input.
2	EN_B	Input	Shaft encoder input B. Only use an NPN shaft encoder.
3	EN_A	Input	Shaft encoder input A. Only use an NPN shaft encoder.
4	EXT_SEN_PNP_IN	Input	External product detect sensor input for PNP connection. Active when the input is high. To use this input, connect Ground from the input signal to Ground on the printer's IO socket.
5	24V_FUSE	Output	24 V DC electrical power output. Protected by a 3 A fuse. Maximum current output: 1.5 A. This output is combined/shared with #12.
6	GROUND	-	
7	STOP_LED_DP	Output	Output to activate red beacon light. Active low, open drain output. 47 K Ohm internal pull-up resistor to +24 V.
8	EXT_SEN_NPN_IN	Input	External product detect sensor input for NPN connection. Active when the input is low. To use this input, connect Ground from the input signal to Ground on the printer's IO socket.

SYSTEM DESCRIPTION

#	Name	Type	Description
9	PRINT_LED_DP	Output	Output to activate green beacon light. Active low, open drain output. 47 K Ohm internal pull-up resistor to +24 V.
10	SP_INPUT	Input	Spare input. Note At the time that this manual was published, this input cannot be used. There is no support for this input in the current software version (1.0.3.0). This input may be usable in a future software version. Active low with 47 K Ohm internal pull-up resistor to +24 V. To use this input, connect Ground from the input signal to Ground on the printer's IO socket.
11	485A	RS485 Communication	RS485A, non-inverting driver output/ receiver input.
12	24V_FUSE	Output	24 V DC electrical power output. Protected by a 3 A fuse. Maximum current output: 1.5 A. This output is combined/shared with #5.
13	GROUND	-	
14	SP_SIG_DP	Output	Spare output. An output will only be triggered when a print is completed. Active low, open drain output. 47 K Ohm internal pull-up resistor to +24 V.
15	ALARM_LED_DP	Output	Output to activate green beacon light. Active low, open drain output. 47 K Ohm internal pull-up resistor to +24 V.

Maximum Label Width

Note The maximum label width depends on the resolution.



Maximum Label Width	Resolution
1.387 m	<ul style="list-style-type: none"> • 600x600 DPI • 300x600 DPI • 150x600 DPI
1.5 m	<ul style="list-style-type: none"> • 600x300 DPI • 600x200 DPI • 600x150 DPI • 600x120 DPI • 600x100 DPI • 300x300 DPI • 300x200 DPI • 300x150 DPI • 300x120 DPI • 300x100 DPI • 150x300 DPI • 150x200 DPI • 150x150 DPI • 150x120 DPI • 150x100 DPI

USER INTERFACE OVERVIEW

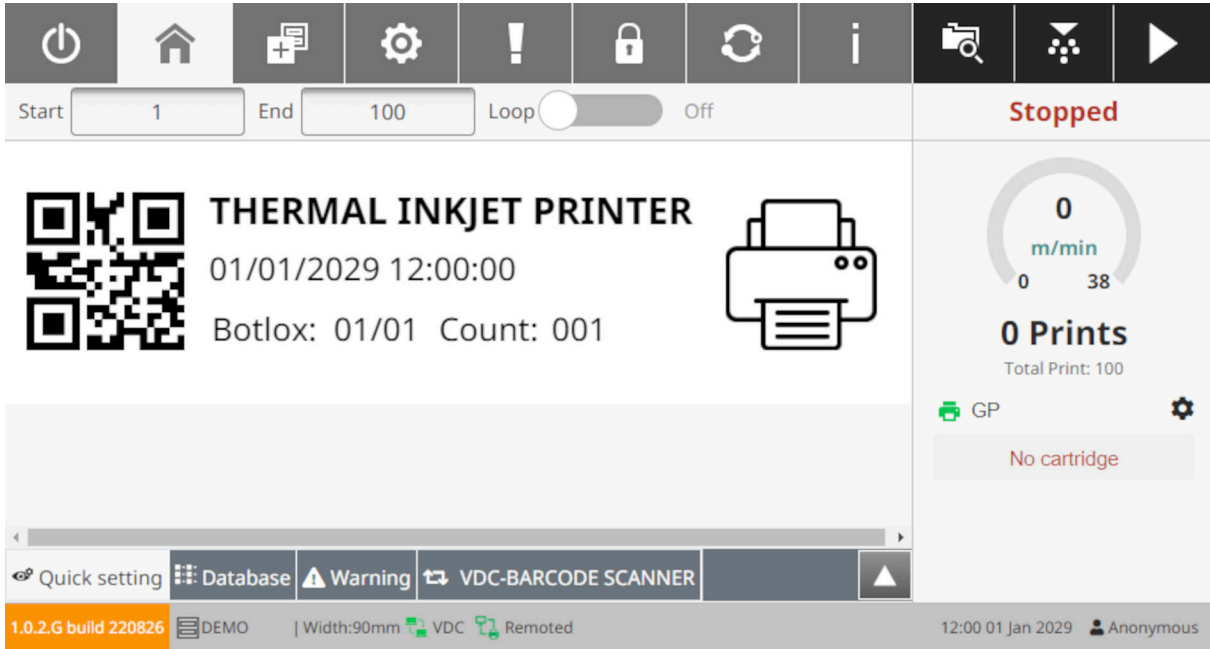







Main Interface Tool Bar



Note Some settings may not be available, when printing.

Item	Name	Description
	Standby	Shut down or restart the printer. Note This setting does not disconnect the printer from the electrical power supply.
	Home	Return to this screen.
	Design	Open the label template design screen: <ul style="list-style-type: none"> Create a new label template Edit a label template Select a label template to print.

SYSTEM DESCRIPTION

Item	Name	Description
	Settings	Open the settings screen: <ul style="list-style-type: none"> • Printhead settings • System settings • Advanced settings • VDC settings • Network settings • Power save settings • Language settings • Font settings.
	Log	Open the log screen: <ul style="list-style-type: none"> • Review and export a log of all user actions • View statistics.
	User	If user mode is enabled: <ul style="list-style-type: none"> • View the current user's details • Change the current user's password. If logged in as an administrator: <ul style="list-style-type: none"> • Create new users • Delete users • Set and edit user permissions • Change passwords of other users.
	Update	Update the software/firmware version.
	About	View information about the software and hardware.
	Open Template	Open a saved label template.
	Purge	Purge the printhead to clear blocked nozzles.
	Start	Start printing.

SYSTEM DESCRIPTION

Item	Name	Description
	Stop	Stop printing.
Start <input data-bbox="256 389 531 468" type="text" value="1"/>	Start index	Set the start index of the counter/ database.
End <input data-bbox="244 533 518 611" type="text" value="1000000"/>	End index	Set the end index of the counter/database.
Loop <input data-bbox="264 680 564 752" type="checkbox"/> Off	Loop	Turn On to repeat data.

Home Screen Print Information

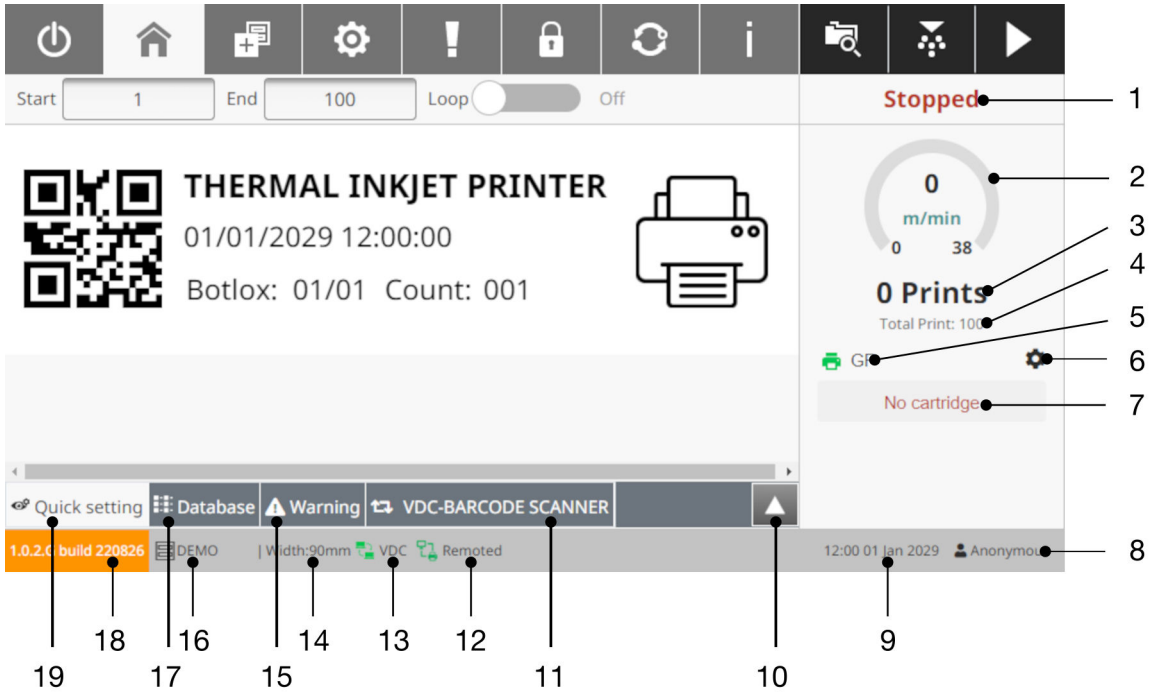

#	Name	Description
1	Printer Status	<ul style="list-style-type: none"> Stopped - The printer is NOT printing Processing - The printer is changing state from Stopped to Ready Ready - The printer is ready to print Printing - The printer is printing.
2	Current Speed	<ul style="list-style-type: none"> If a shaft encoder is not used to measure the production line speed, the value shown will be the number entered in <i>Settings > System Settings > Encoder > Internal > Speed (m/min)</i> If a shaft encoder is used, the value shown will be the production line speed measured by the shaft encoder.
3	Number of Prints	<ul style="list-style-type: none"> Shows the number of prints that have been made Each print will increase the value by 1 Range: 0 to 1,000,000,000.

SYSTEM DESCRIPTION





#	Name	Description
4	Total Print	<ul style="list-style-type: none"> Shows the total number of pages for the current print job If the label template contains a counter, the value will be equal to the counter value If the label template contains a database and a counter, the value will equal the number of rows in the database file, even if the counter value is bigger If the label template contains fixed text only, the value will be 1 Turn <i>Loop On</i> for unlimited printing.
5	Printhead Information	<ul style="list-style-type: none"> Printhead type Printhead status.
6	Cartridge Information	<ul style="list-style-type: none"> Status Label Ink volume Nozzle check status Prints remaining Prints per 10 ml.
7	Cartridge Status	<ul style="list-style-type: none"> Cartridge connection status Ink volume.
8	Username	Name of the logged in user.
9	System Clock	<ul style="list-style-type: none"> Displays the current system date/time To change the value, see Common on page 85.
10	Quick setting	Quick access to print alignment settings, see Alignment on page 65 .
11	VDC-Barcode Scanner	<p>Note This setting is visible only if the <i>Connection</i> setting in the <i>VDC</i> settings is set to <i>Barcode scanner</i>.</p> <p>Select to view VDC (Variable Data Connection) barcode data, see VDC Settings on page 87.</p>
12	Remote status	Displays if <i>Remote</i> is turned on, see Remote on page 81 .
13	VDC status	Displays if VDC (Variable Data Connection) is turned on, see VDC Settings on page 87 .
14	Width	Displays the current label template width.
15	Warning	View printer warning messages.
16	Label name	Displays the name of the loaded label template.

SYSTEM DESCRIPTION

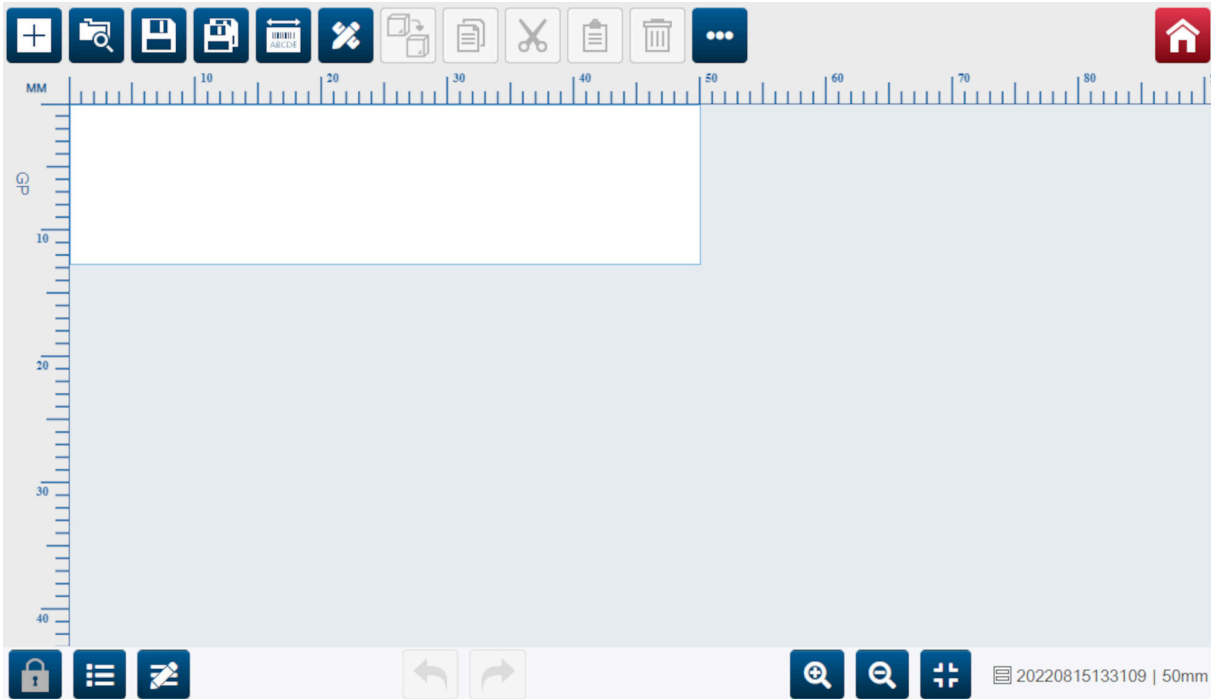





#	Name	Description
17	Database	View database information.
18	Software version	Displays the current software version
19	Quick setting	Quick access to print alignment settings, see Alignment on page 65 .

Label Template Designer













Item	Name	Description
	New	Create a new label template.
	Open	<ul style="list-style-type: none"> Preview and open saved label templates Copy existing label templates Delete label templates.
	Save	Save the current label template.
	Edit	Edit the label template width.

SYSTEM DESCRIPTION

Item	Name	Description
	Object	Add an object/element to the label template: <ul style="list-style-type: none"> • Text • Counter • Database • Barcode • Graphics • Clocks • Shift code • Line • Boxlot.
	Clone	Clone and automatically paste the selected object/element. This setting includes the options listed below: <ul style="list-style-type: none"> • Auto mode - Disable or enable the <i>Direction</i>, <i>Distance Y (mm)/Distance X (mm)</i> and <i>Count</i> settings. • Direction - Set the direction that cloned objects will be pasted, from the original object: <ul style="list-style-type: none"> • Vertical - Cloned objects will be pasted below the original object. • Horizontal - Cloned objects will be pasted to the right of the original object. • Distance Y (mm)/Distance X (mm) - Set the horizontal/vertical space between each cloned object and the original object. • Count - Set the number of times that the object will be cloned.
	Copy	Copy the selected object/element.
	Cut	Cut the selected object/element.
	Paste	Past a copied or cut object/element.
	Delete	Delete the selected object/element.

SYSTEM DESCRIPTION

Item	Name	Description
	More	View more options: <ul style="list-style-type: none"> • Import template - Import a label template from a USB memory device • Export template - Export a label template to a USB memory device • Remove database - Remove the database that was last loaded.
	Home	Return to the home screen.
	Lock Template	Lock the label template layout area. If the template is locked, the user will not be able to adjust the template. The user will be able to access the tool bar.
	Objects	Open a list of objects that are used in the current label template.
	Properties	View and edit the properties of the selected object.
	Undo	Undo the last action.
	Redo	Redo the last action.
	Zoom In	Zoom into the label template.
	Zoom Out	Zoom out of the label template.
	Zoom Reset	Reset the zoom.

PART 3 INSTALLATION

UNPACKING

Remove the controller, printheads and accessories (e.g. encoder and sensor) from the packaging.

The equipment delivered will vary according to the specific order. Check the contents of the shipment against the packing list and report any differences to Domino.

LOCATION

Position the equipment:

- Where they are electrically isolated from other equipment.
- Where the temperature remains within the specified range, see [Specification on page 23](#).
- Where the relative humidity remains within the specified range, see [Specification on page 23](#).
- Close to an accessible power outlet, to ensure power can be disconnected quickly.
- Where access to pipes, cables and electrical connections is not blocked.

VERTICAL INSTALLATION

To mount the G50i:

1. Fit the clamp onto the controller.

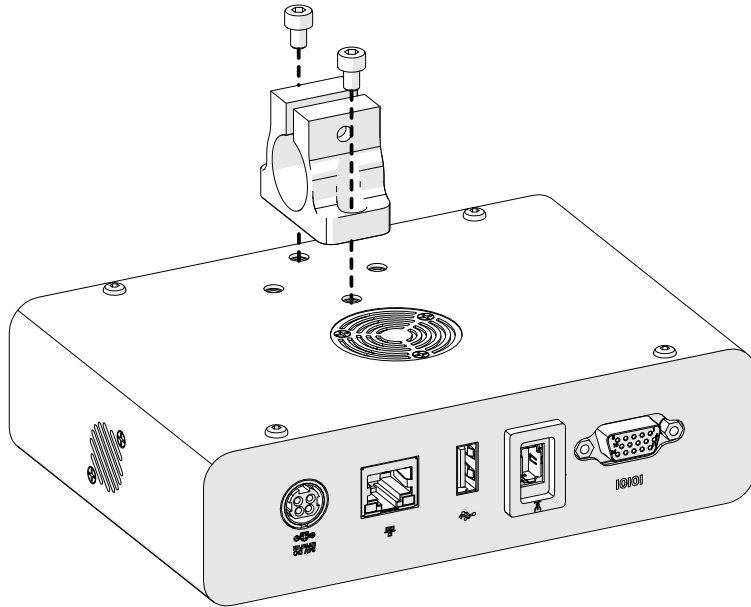

2. Fit the mounting clamp, and a round bar onto the printhead.

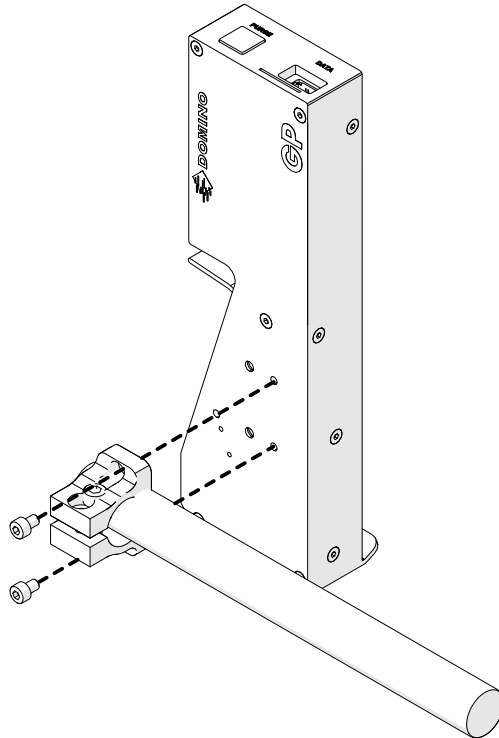

INSTALLATION

3. Fit the base clamp and 1 of the round bars onto the conveyor/production line.

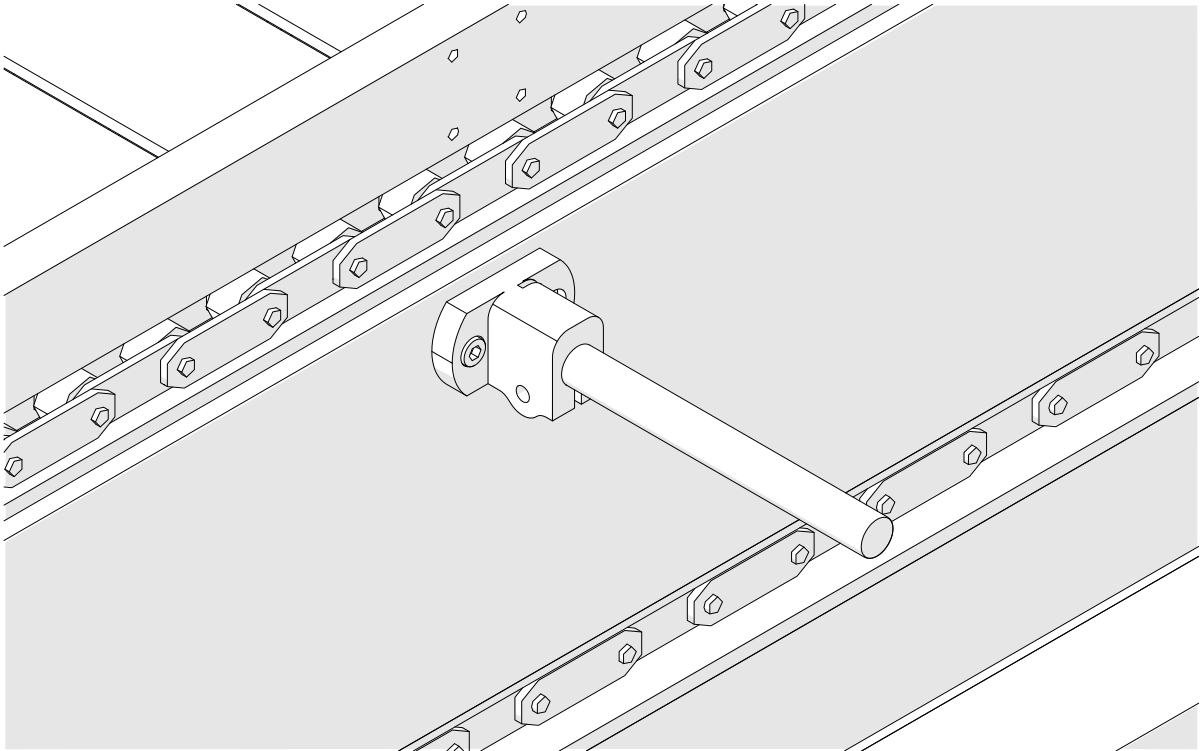

4. Fit a round bar and clamp as shown below.

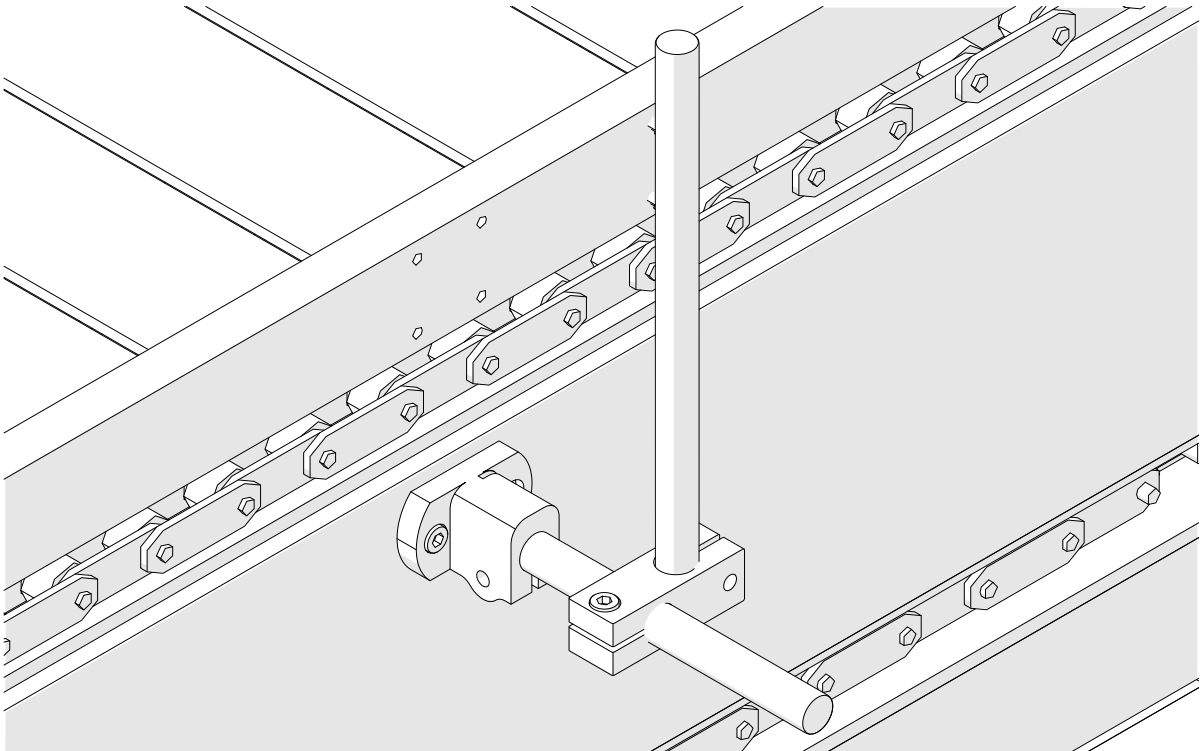

INSTALLATION

5. Fit another round bar and clamp as shown below.

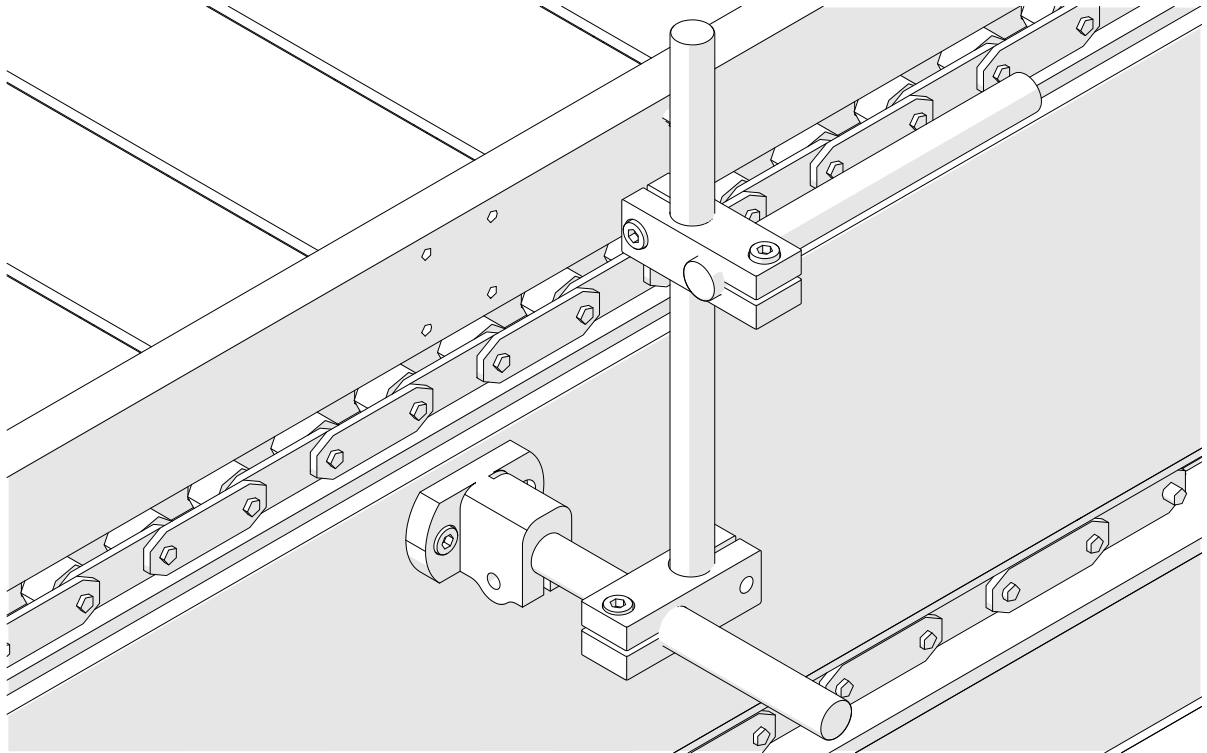

6. Fit the controller

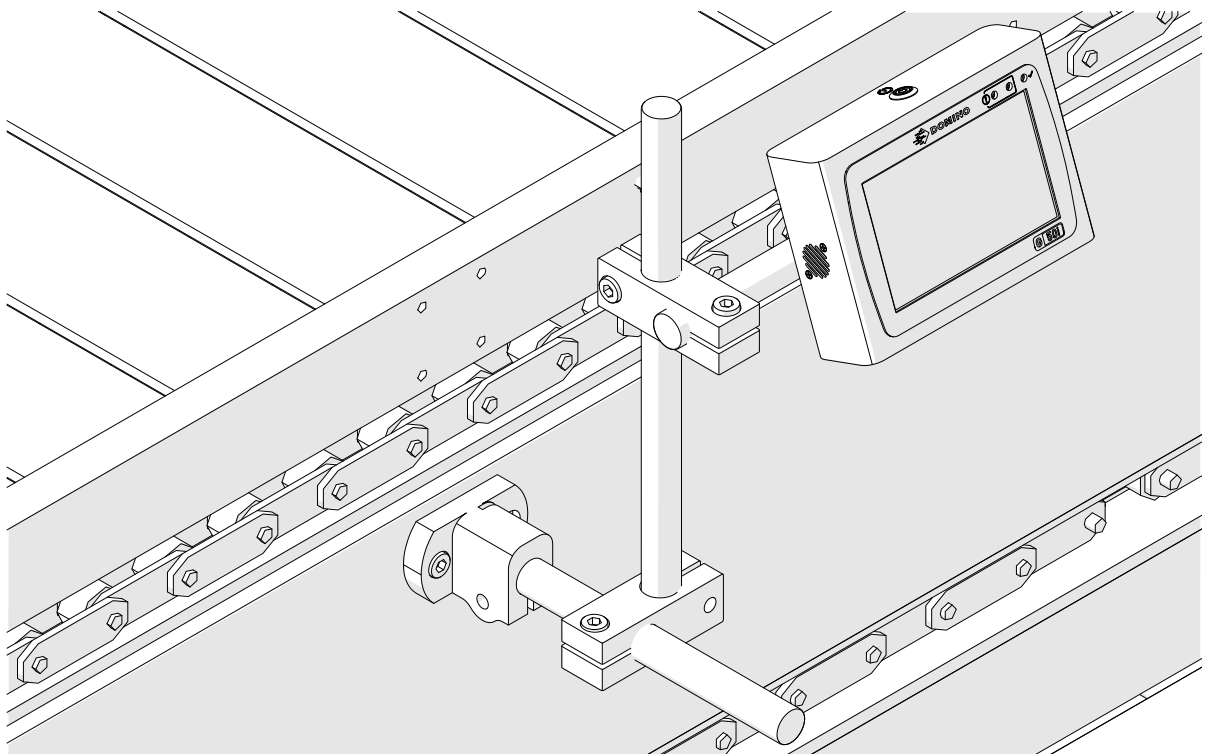

INSTALLATION

7. Fit the printhead.

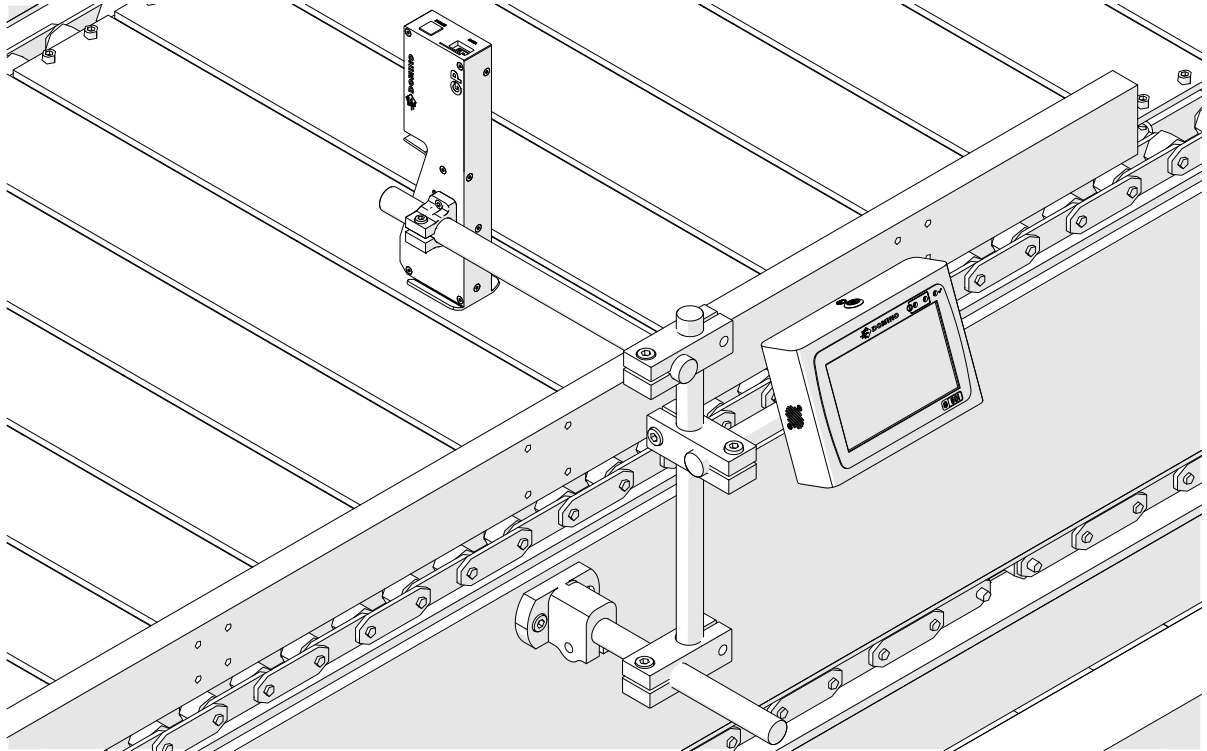

HORIZONTAL INSTALLATION

To mount the G50i:

1. Fit the clamp onto the controller.

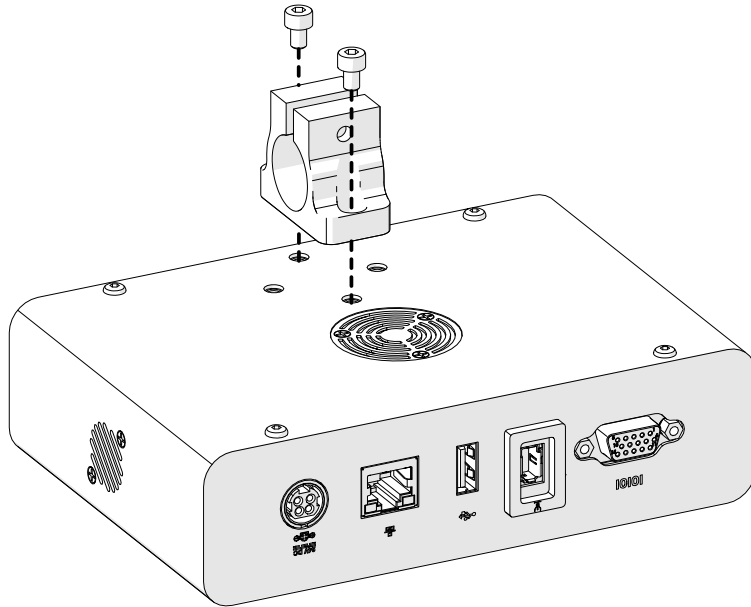

2. Fit the mounting clamp, and a round bar onto the printhead.

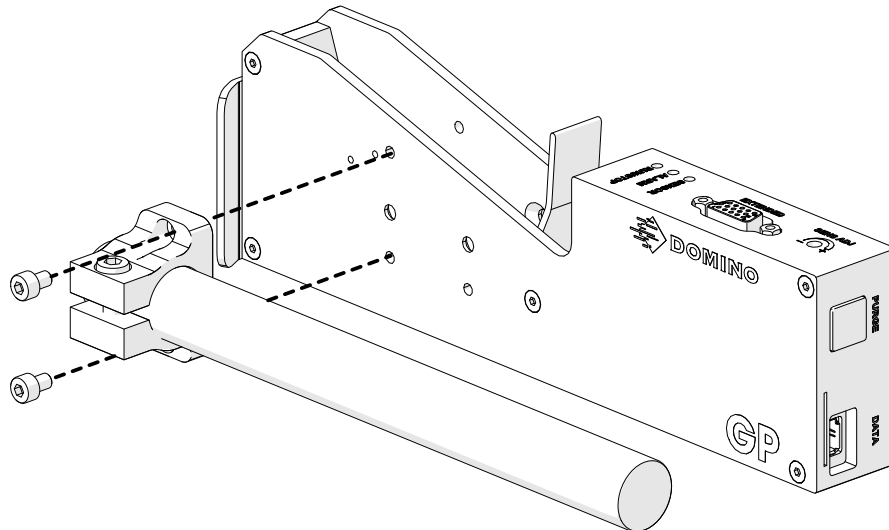

INSTALLATION

3. Fit the base clamp and 1 of the round bars onto the conveyor/production line.

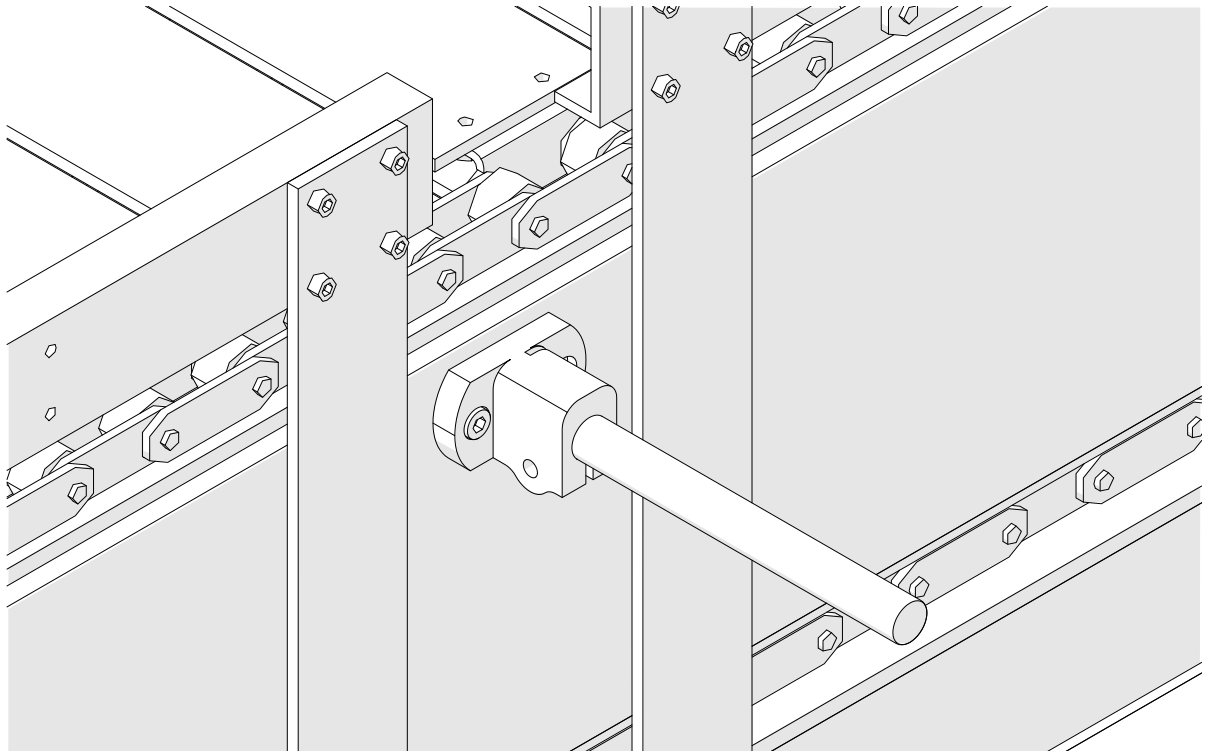

4. Fit a round bar and clamp as shown below.

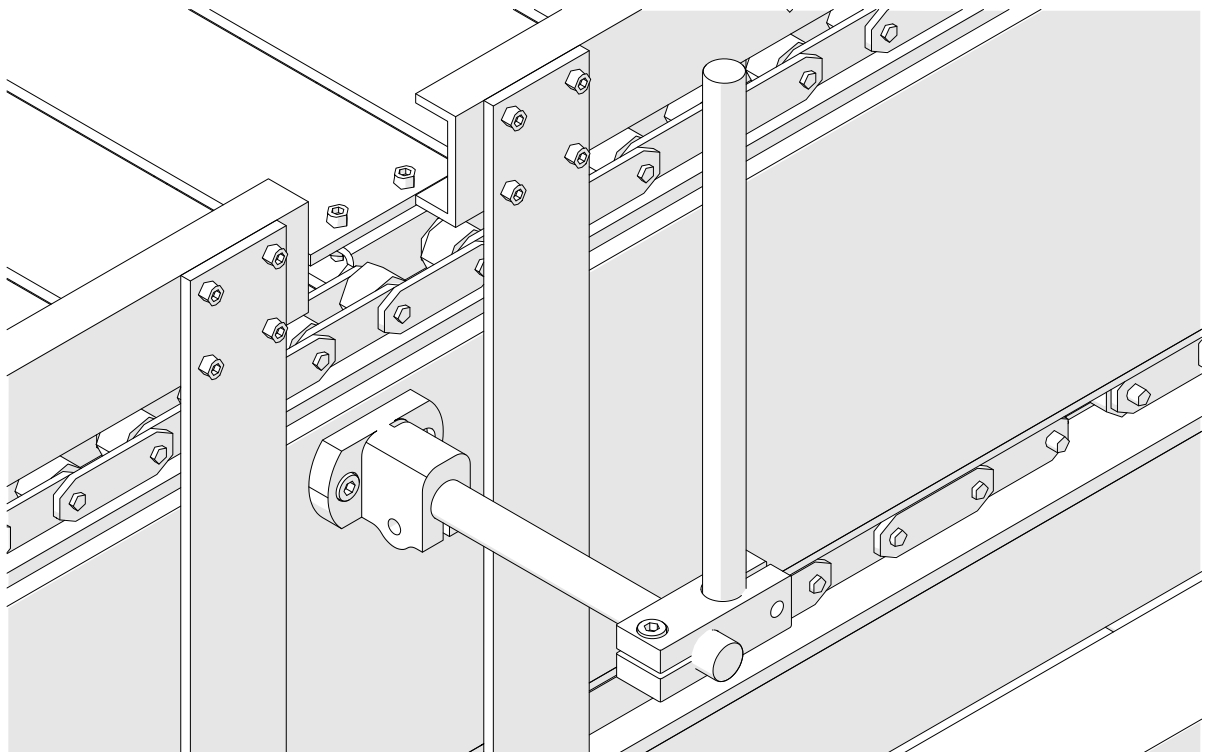

INSTALLATION

5. Fit the printhead.

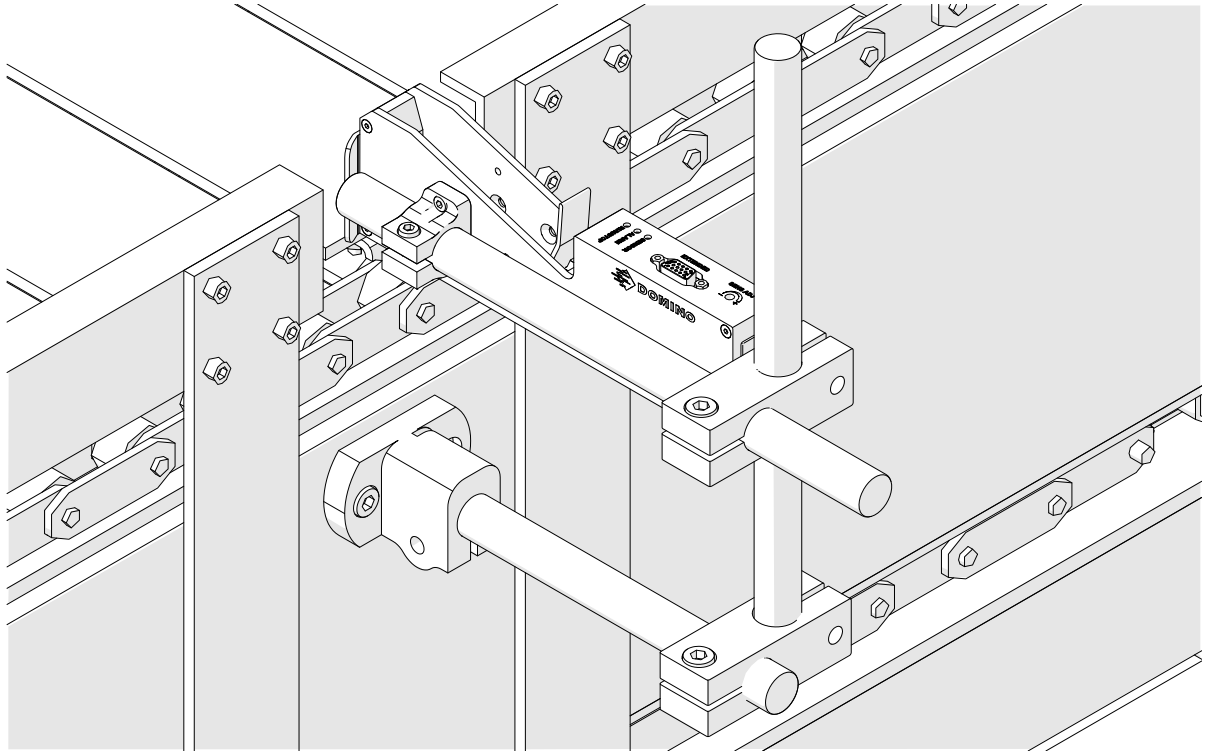

6. Use product guides on the conveyor/production line, to protect the printhead from damage/impact.

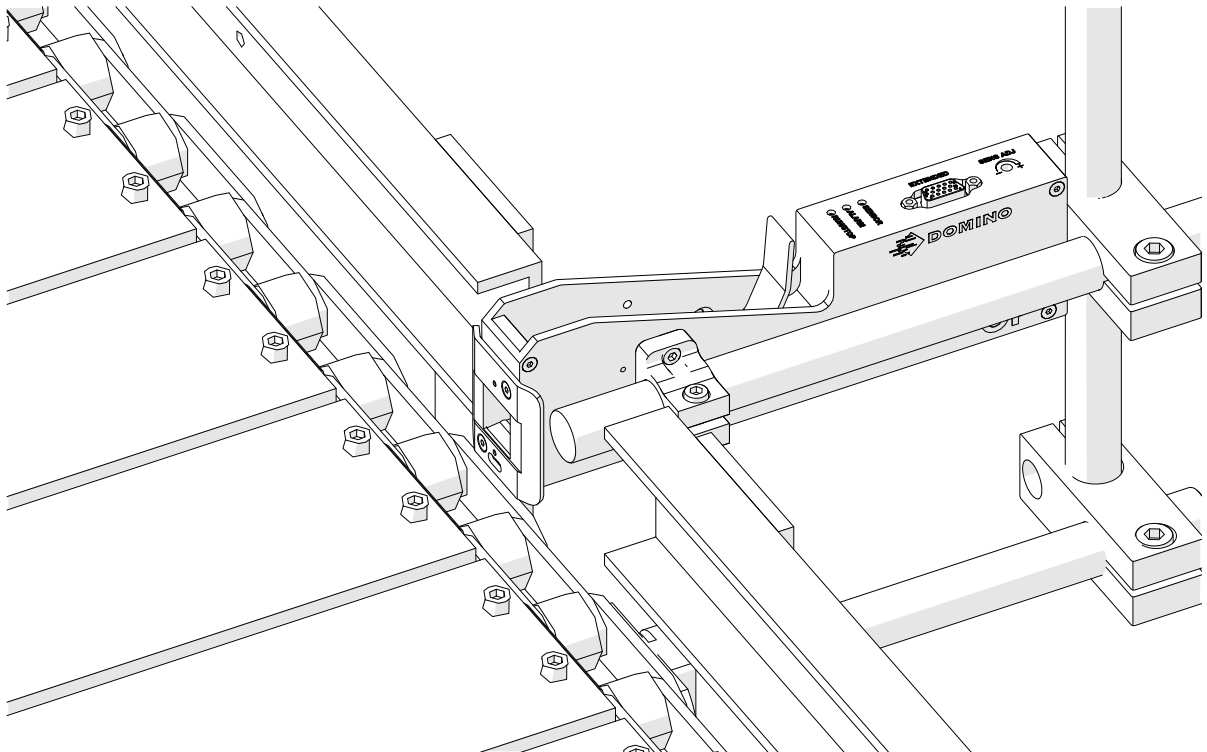

INSTALLATION

7. Fit another round bar.

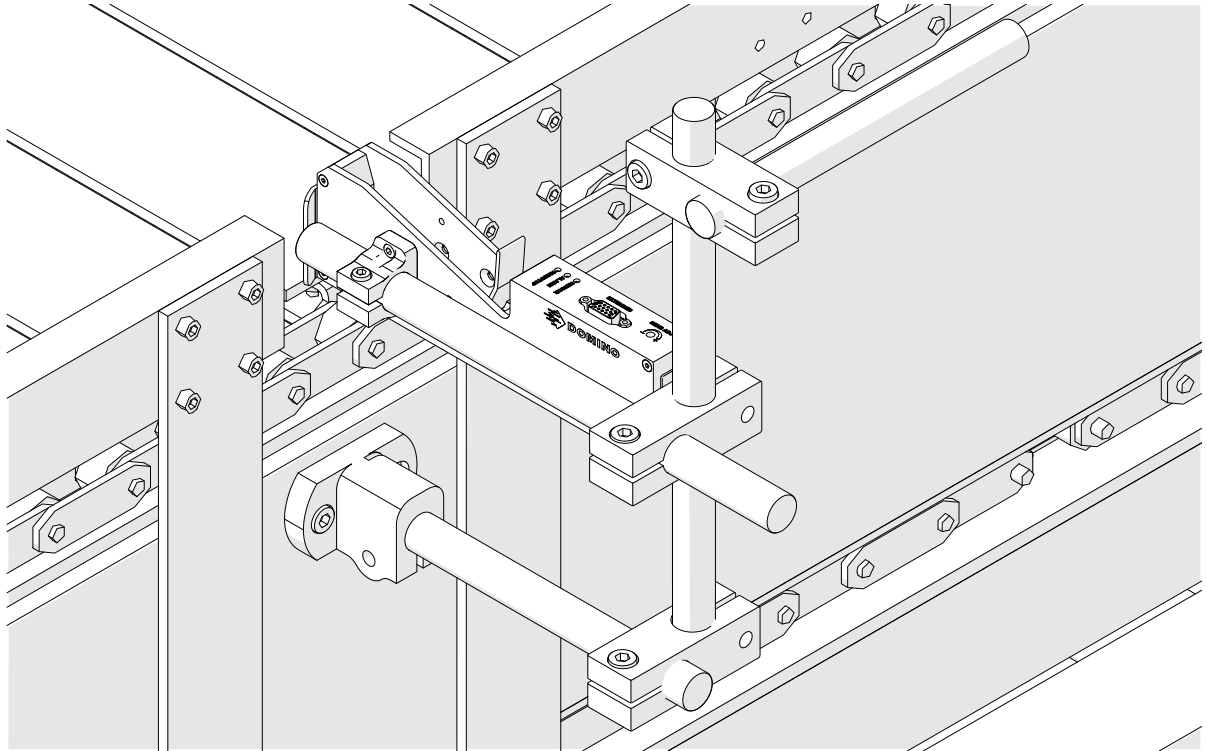

8. Fit the controller.

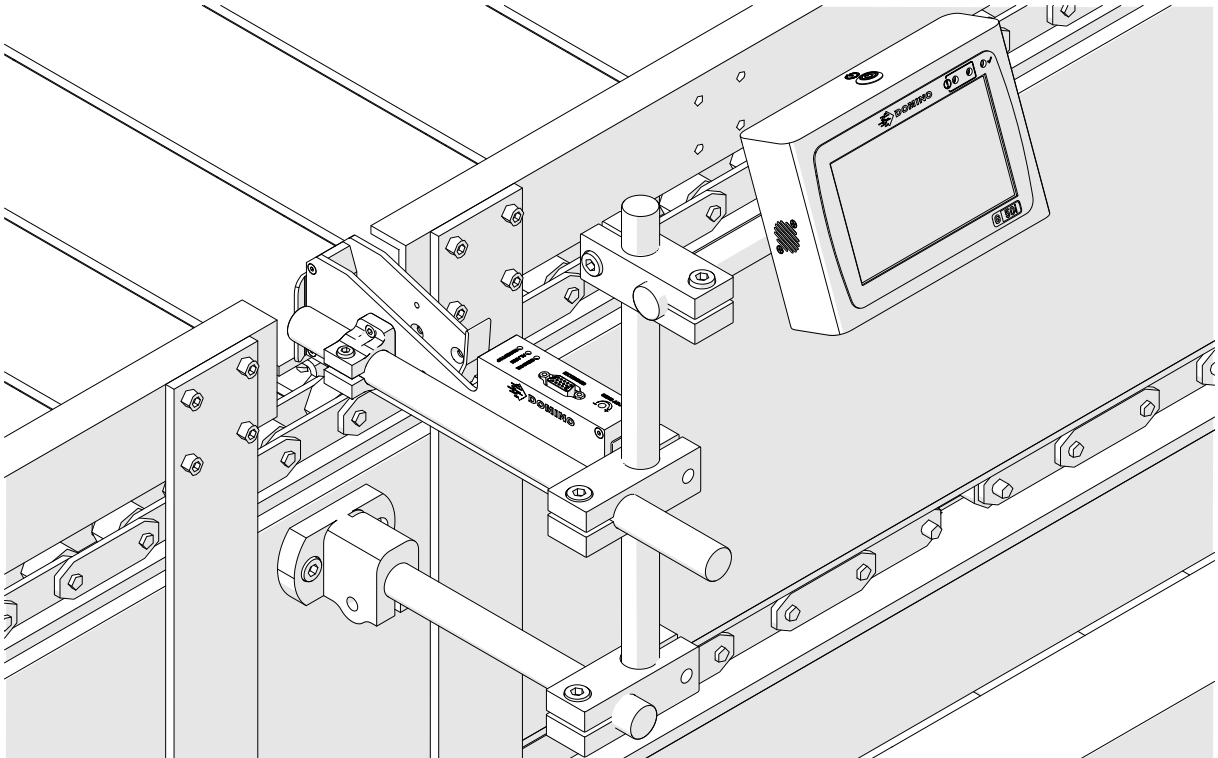

ANTI SHOCK (OPTIONAL) INSTALLATION

Pinch Point. Risk of Injury.



Keep hands/fingers out of the anti shock clamp.

Hands and fingers may become caught in the anti shock clamp. If the anti shock clamp closes on hands and fingers, injury may occur.

Required tools: 3 mm hex key

To install the optional printhead anti shock clamp:

1. Install the screw labeled (1) in the image below.
2. Compress the clamp and install the screw labeled (2) in the image below.

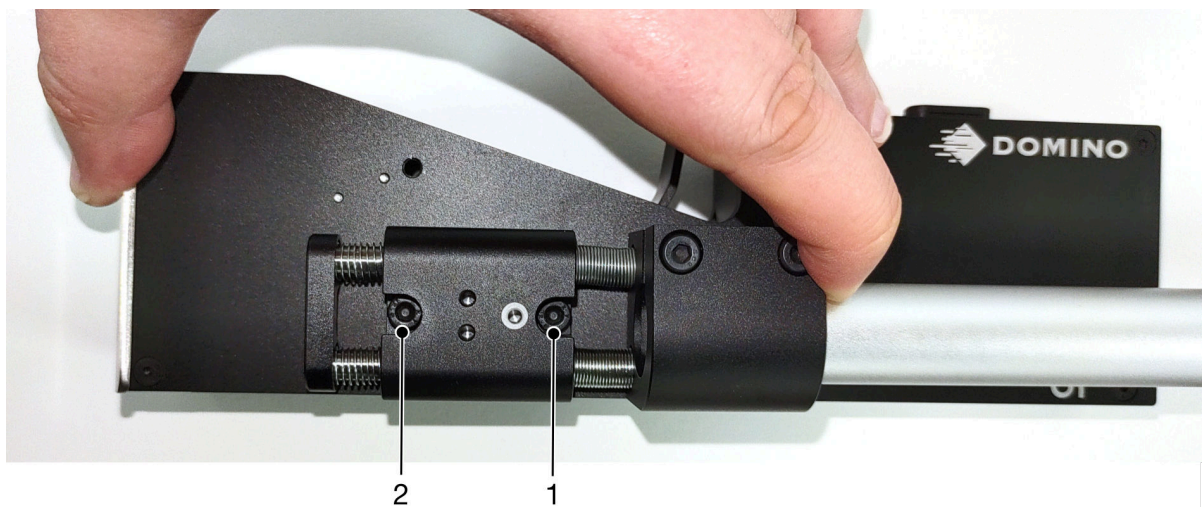

PRINTHEAD ORIENTATION

Side View

The illustration below and the illustration on the next page show the correct printhead orientations and the orientations to avoid.

- Orientations A1, A2 and A3 are recommended.
- Orientations A7 and A8 are not recommended. These orientations will stop 1/3 of the ink in the cartridge reaching the nozzles.
- Do not install the printhead in orientations A4, A5 and A6.

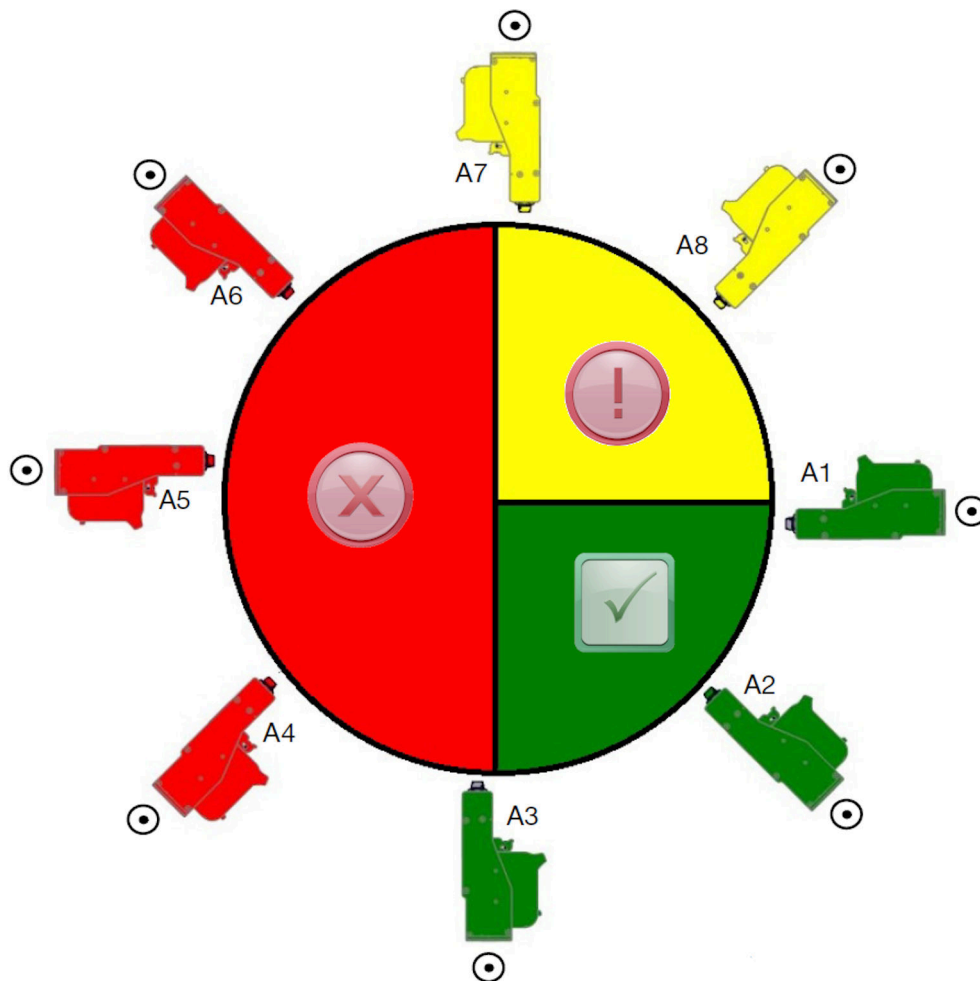

Front View

- Orientations B2, B3 and B4 are recommended.
- If the printhead is installed in orientation B1 or B5, angle the printhead downwards by a minimum of -4° . Also, if the vertical DPI is set to 300, select the nozzle row that is lowest to the ground for printing, see [Print Quality on page 64](#).
- Orientations B6, B7 and B8 are not recommended. These orientations will stop 1/3 of the ink in the cartridge reaching the nozzles.

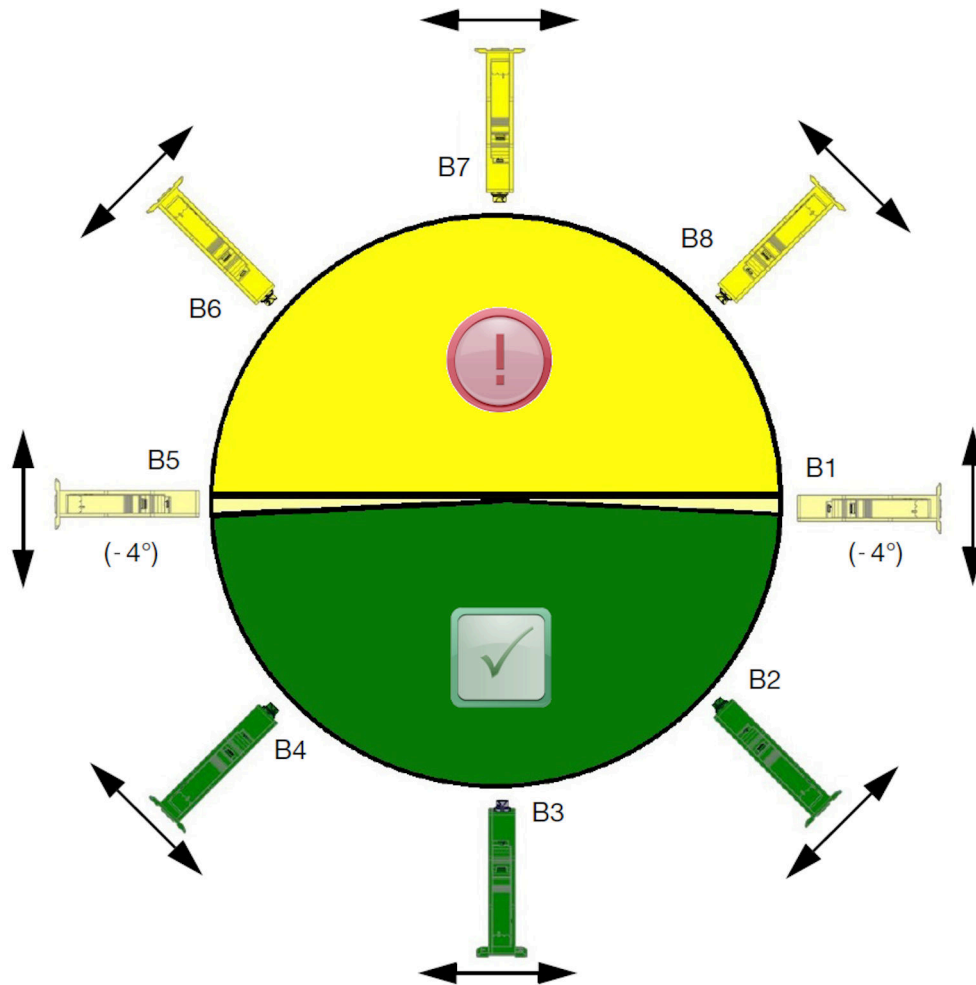

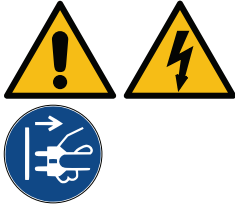
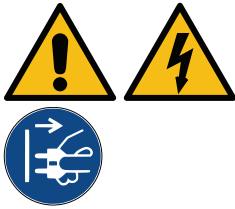

PRINTHEAD CONNECTION

WARNING Electricity. Risk of injury.	
	<p>Turn off the equipment and disconnect the power supply before disconnecting or making electrical connections.</p> <p>When powered on, the controller contains live electrical components. Physical contact with live electrical components can result in an electric shock.</p>
CAUTION Electricity. Risk of damage to equipment.	
	<p>Turn off the equipment and disconnect the power supply before disconnecting or making electrical connections.</p> <p>When powered on, the equipment contains live electrical components.</p> <p>An incorrect electrical connection can damage the equipment.</p>

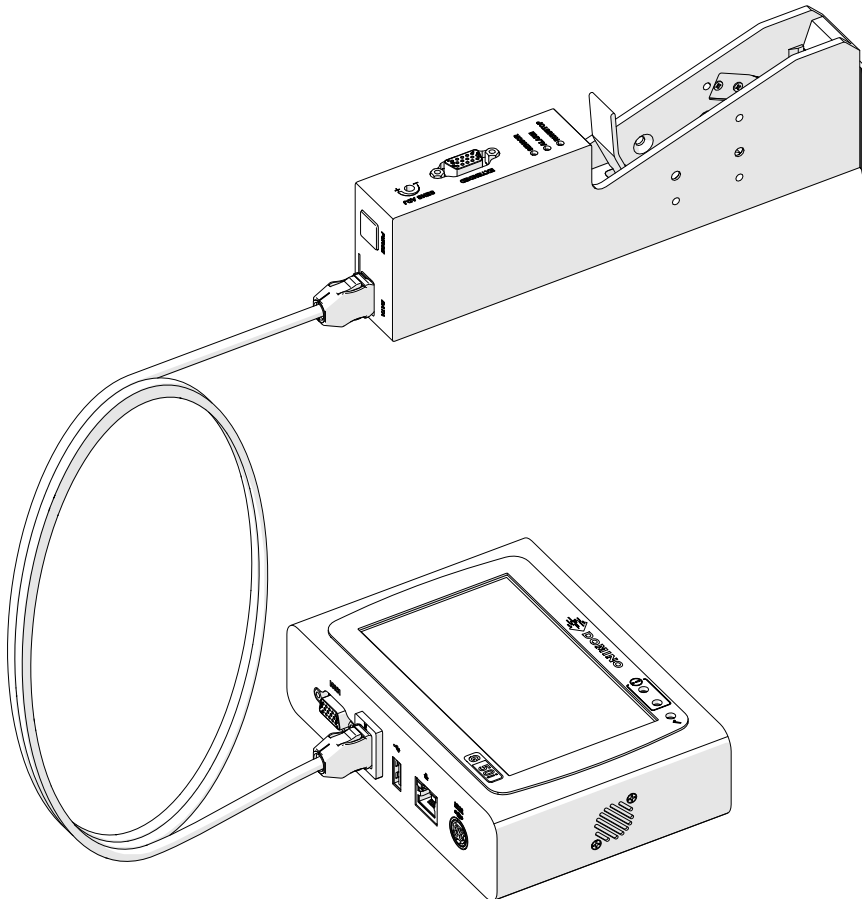
The image below shows how to connect the printhead to the controller.



INK CARTRIDGE INSTALLATION

WARNING Hazardous Chemicals. Risk of eye and skin damage.	
	<p>Wear protective equipment such as gloves and glasses when near the printer.</p> <p>Contact with chemicals can cause skin or eye damage. Refer to Safety Data Sheet.</p>
CAUTION Fragile Electrical Contacts. Risk of Equipment Damage.	
	<p>Do not force the cartridge into the printhead.</p> <p>Be careful when inserting the cartridge. Forcing the cartridge against the electrical contacts can break the contacts on the printhead circuit board.</p>

To install an ink cartridge:

1. Remove the protective cover from the ink cartridge.
2. If the cartridge is new, clean the electrical contacts with an ethanol wipe, to remove corrosion protection.

Note Cleaning wipe part number: EPT039697

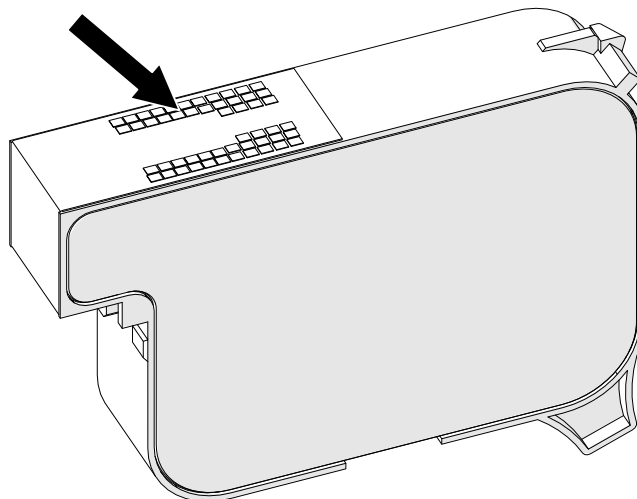

3. Use a new/clean lint-free cloth to wipe the ink cartridge nozzles at a 45° angle.

Note The 45° angle stops debris from one nozzle contaminating the next nozzle.

CAUTION

Sensitive Equipment. Risk of Equipment Damage.



Do not use an ethanol wipe or any other chemical to clean the cartridge nozzles.

Use a new/clean lint-free cloth. If chemicals are used to clean the cartridge, the nozzles may be damaged.

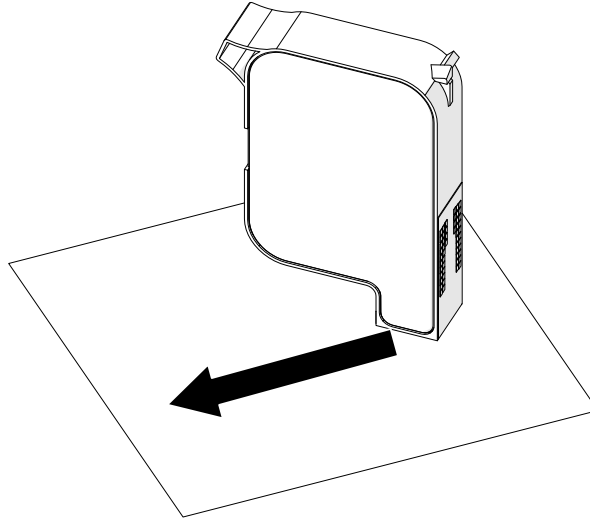

4. Insert the ink cartridge into the printhead and close the printhead latch.

CAUTION

Fragile Electrical Contacts. Risk of Equipment Damage.



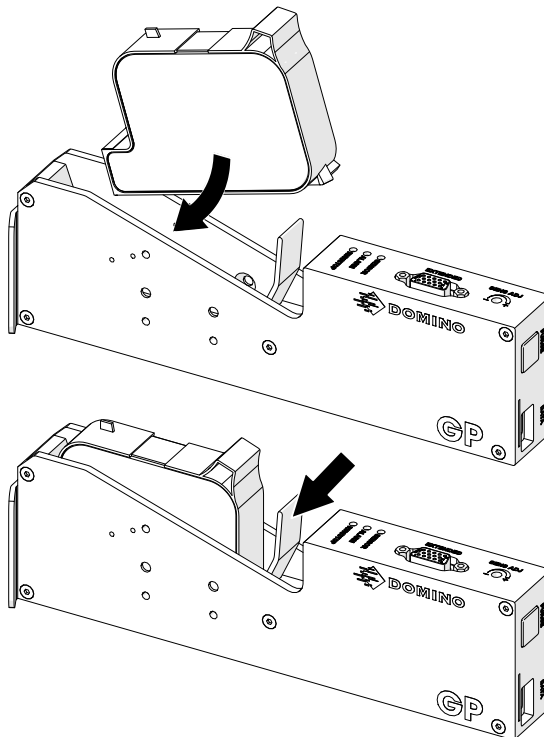

Do not force the cartridge into the printhead.

Be careful when inserting the cartridge. Forcing the cartridge against the electrical contacts can break the contacts on the printhead circuit board.

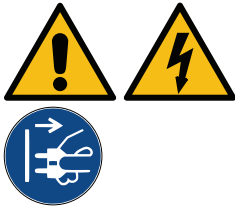

CONTROLLER ELECTRICAL SUPPLY

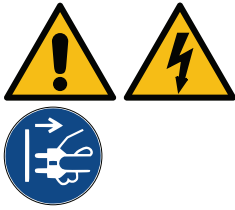
WARNING Electricity. Risk of injury.	
	<p>Turn off the equipment and disconnect the power supply before disconnecting or making electrical connections.</p> <p>When powered on, the controller contains live electrical components. Physical contact with live electrical components can result in an electric shock.</p>
WARNING Obstacle Hazard. Risk of Injury.	
	<p>Do not install the equipment, cables, conduits or accessories in a walkway, or in a location where they may cause an obstacle hazard.</p> <p>If the equipment, cables, conduits or accessories are installed in a walkway, or in location where they may cause an obstacle hazard, injury to personnel may occur.</p>
CAUTION Electricity. Risk of damage to equipment.	
	<p>Turn off the equipment and disconnect the power supply before disconnecting or making electrical connections.</p> <p>When powered on, the equipment contains live electrical components.</p> <p>An incorrect electrical connection can damage the equipment.</p>

Connect the controller and electrical power adapter to a power supply using a suitable plug and socket outlet. Make sure the power supply is accessible and close to the equipment, so it can be quickly disconnected. If a fused power connector is used, fit it with a 5 A fuse. If a fused power connector is not used, a circuit breaker or fuse rated at 5 A is required.

The supply must be free from electrical noise. Domino can give advice on suitable devices to ensure trouble-free operation.

Only use the electrical power supply adapter listed below:

- Manufacturer: MEAN WELL ENTERPRISES CO. LTD
- Model: GST60A24

INSTALLATION

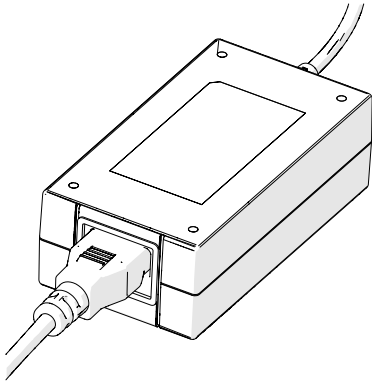

Setup Adapter

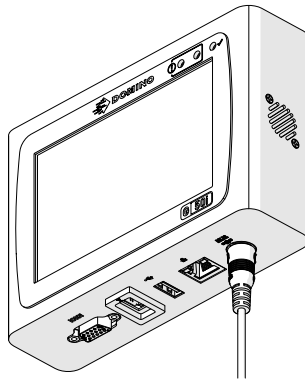

Connect Adapter to Controller

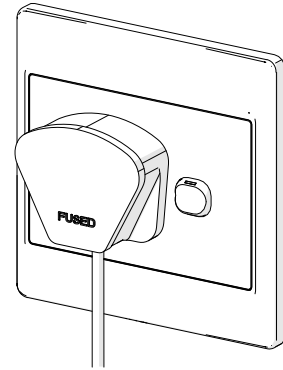

Connect adapter to wall outlet

PRINTHEAD PRODUCT DETECT SENSOR CALIBRATION

To calibrate the printhead's internal product detect sensor:

1. Put the print surface or a box in front of the printhead so it covers the product detect sensor.
2. The sensor LED on the printhead should turn on to indicate that the sensor is triggered.

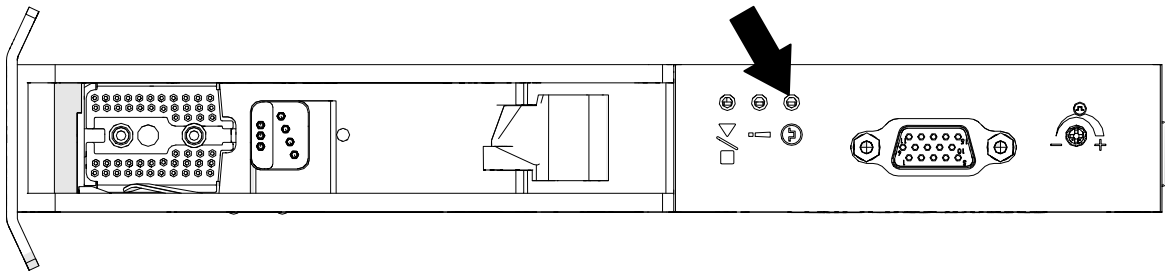

3. If the sensor LED did not turn on, use a small screw driver to turn the sensor adjustment screw on the printhead clockwise until the sensor LED turns on.

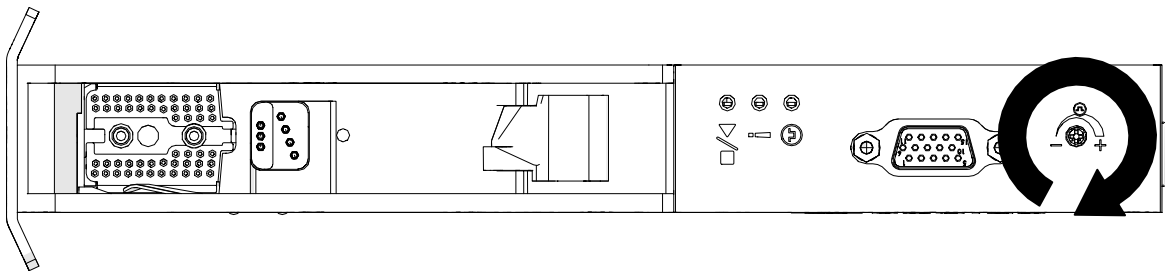

4. Remove the print surface or box from in front of the printhead.
5. The sensor LED should now turn off. If the sensor LED did not turn off, turn the sensor adjustment screw anti clockwise until the sensor LED turns off.

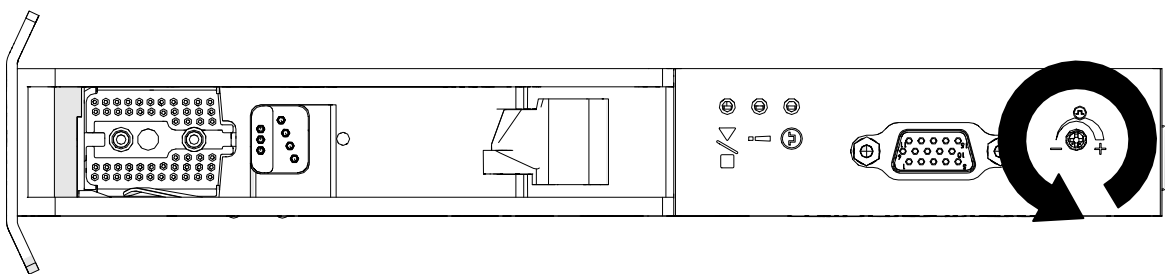

EXTERNAL DEVICE CONNECTION

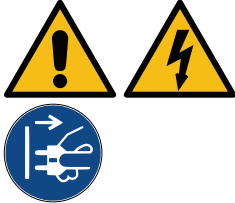
WARNING Electricity. Risk of injury.	
	<p>Turn off the equipment and disconnect the power supply before disconnecting or making electrical connections.</p> <p>When powered on, the controller contains live electrical components. Physical contact with live electrical components can result in an electric shock.</p>

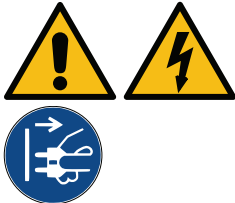
CAUTION Electricity. Risk of damage to equipment.	
	<p>Turn off the equipment and disconnect the power supply before disconnecting or making electrical connections.</p> <p>When powered on, the equipment contains live electrical components.</p> <p>An incorrect electrical connection can damage the equipment.</p>

The printer can operate with an external product detect sensor, shaft encoder and alarm beacon at the same time.

Use a male, 15-way, high density, D plug to connect to the controller's IO socket.

External Product Detect Sensor

The printer supports NPN and PNP connections.

The sensor is powered from the printer's IO socket.

After the product detect sensor has been connected, the printer settings need to be defined, see [Print Mode - Continuous](#), and [Print Trigger - Sensor](#) on page 69.

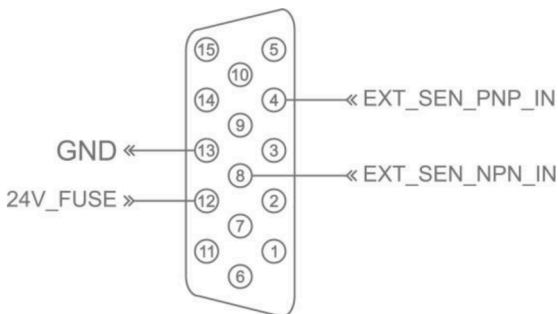

#	Value
12	24 V DC electrical power output. Protected by a 3 A fuse. Maximum current output: 1.5 A
13	Ground

INSTALLATION

#	Value
4	External product detect sensor input for PNP connection. Active when the input is high. To use this input, connect Ground from the input signal to Ground on the printer's IO socket.
8	External product detect sensor input for NPN connection. Active when the input is low. To use this input, connect Ground from the input signal to Ground on the printer's IO socket.

External Shaft Encoder

It is recommended to use an external shaft encoder to measure the production line speed. An external shaft encoder will make sure that the best print quality is achieved.

Only use an NPN shaft encoder.

Use the formula below to calculate the diameter of the shaft encoder wheel:

D = Diameter of encoder wheel (Inches)

R = Encoder PPR (Pulses Per Revolution)

$$D = R / (\pi \times 600)$$

For example, if the encoder has a resolution (R) of 3600 PPR, the diameter of the encoder wheel = 1.90985 Inches (48.5 mm)

To setup the encoder settings, see [Encoder Input - External on page 67](#).

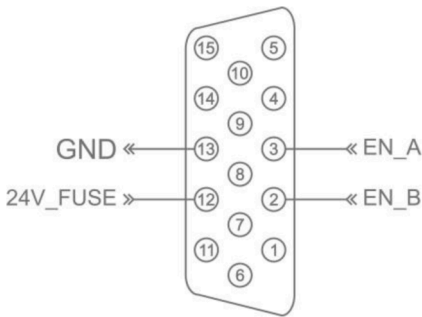

#	Value
12	24 V DC electrical power output. Protected by a 3 A fuse. Maximum current output: 1.5 A.
13	Ground
2	Shaft encoder input B.
3	Shaft encoder input A.

Alarm Beacon

An alarm beacon can be connected to let users monitor the printer's status from a distance.

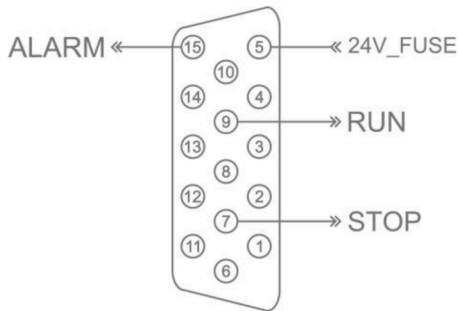

#	Value	Description
5	24 V	24 V DC electrical power output. Protected by a 3 A fuse. Maximum current output: 1.5 A.
7	STOP	Output to activate red beacon light. Active low, open drain output. 47 K Ohm internal pull-up resistor to +24 V. When this output is active, the printer has stopped printing because of one of the reasons below: <ul style="list-style-type: none"> • No ink cartridge • Invalid ink cartridge • Empty ink cartridge • Speed limit • VDC/Real Time Printing Speed Overload
9	RUN	Output to activate green beacon light. Active low, open drain output. 47 K Ohm internal pull-up resistor to +24 V. This output is active when one of the reasons below occurs: <ul style="list-style-type: none"> • The user has selected the "Print" button. • The printer is printing with no problems.
15	ALARM	Output to activate green beacon light. Active low, open drain output. 47 K Ohm internal pull-up resistor to +24 V. This output is active when the printer has a problem, but it is still able to print. For example, the ink level may be low.

IO Connection

The printer can make an output signal when printing is done.

To setup the output signal, see [IO Signal on page 83](#).

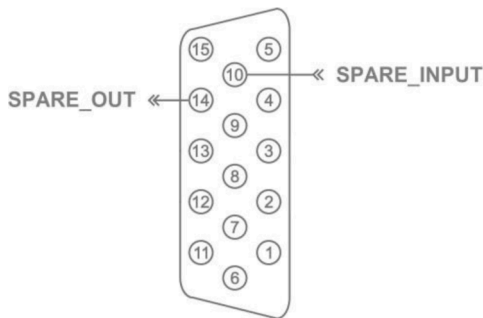

#	Value	Description
10	Spare Input	<p>Note At the time that this manual was published, this input cannot be used. There is no support for this input in the current software version (1.0.3.0). This input may be usable in a future software version.</p> <p>Active low with 47 K Ohm internal pull-up resistor to +24 V. To use this input, connect Ground from the input signal to Ground on the printer's IO socket.</p>
14	Spare Out	<p>Active low, open drain output.</p> <p>47 K Ohm internal pull-up resistor to +24 V.</p>

PRINthead SETTINGS

To view the printhead settings, from the *Home* screen, select the *Settings* icon.

Print Quality

To view the print quality settings:



1. From the *Home* screen, select the *Settings* icon:
2. The *Print Quality* settings listed below are available:

Setting Name	Description
Resolution	Set the printing resolution: 600x600, 600x300, 600x200, 600x150, 600x120, 600x100, 300x600, 300x300, 300x200, 300x150, 300x120, 300x100, 150x600, 150x300, 150x200, 150x150, 150x120 and 150x100 dpi. The resolution will change the maximum printing speed. See, Printing Speed Table.
Channel	Select which side of the ink cartridge will be used for printing: <ul style="list-style-type: none"> • ODD: The ODD side nozzles will be used to print only. • EVEN: The Even side nozzles will be used to print only. <p>Note If 600dpi resolution is used, both nozzle sides will print together.</p>
Direction	Set the printing direction of the printhead: <ul style="list-style-type: none"> • Left to right (L2R) • Left to right reverse (L2RR) • Right to left (R2L) • Right to left reverse (R2LR)

Alignment

To view the printhead alignment settings:

1. From the *Home* screen, select the *Settings* icon:
2. The *Alignment* settings listed below are available:



Setting Name	Description
Forward offset (mm)	Set the distance between the point where the product detect sensor is triggered and the point where the print is made.
Disable sensor (mm)	Set a distance to disable the product detect sensor after it has been triggered. The purpose of this setting is to prevent multiple prints on a product.
Fixed length (mm)	Note This setting is used if the "Repeat Times" setting is different from 0 with "Sensor Mode". Set the distance between 2 repeat prints.
Reverse offset (mm)	Note This setting is used if "Bi-Direction" mode is enabled. See Bi-Direction on page 70 . Set the distance for the second print, between the point where the product detect sensor is triggered and the point where the print is made.

SYSTEM SETTINGS

To view the system settings:

1. From the *Home* screen, select the *Settings* icon:



2. Select the *System Settings* icon:



Encoder Input - Internal

To setup an internal encoder with a fixed printing speed:

1. From the *Home* screen, select the *Settings* icon:



2. Select the *System Settings* icon:



3. Set the *Encoder input* setting to *Internal*.
4. Adjust the *Speed (m/min)* setting.

Encoder Input - External

Use this option to measure the production line speed with a shaft encoder. To use this option, a shaft encoder must be connected to the controller. See, [External Shaft Encoder on page 61](#).

If the settings are incorrect, it will affect the print quality.

To setup an external shaft encoder to measure the production line speed:

1. From the *Home* screen, select the *Settings* icon:



2. Select the *System Settings* icon:



3. Set the *Encoder input* setting to *External*.

4. Setup the settings listed below:

Setting Name	Description
Pulse/Revolution	Enter the number of pulses that the shaft encoder will make for each revolution. Default value: 3600
Diameter (mm)	Enter the diameter of the shaft encoder wheel. Default value 48.51 mm
Resume encoder	Select the encoder rotation direction. Default value: Auto. <ul style="list-style-type: none"> • Auto (both directions are valid) • Clockwise • Counter clockwise.

Print Trigger - Continuous

Continuous print trigger mode is often used in web, pipe or roll printing applications (without a sensor mark).

Continuous print trigger mode can be setup in 3 different ways:

- It can let the printer operate without a product detect sensor.
- It can let a signal from a product detect sensor, trigger the start of a print run. Printing will continue until the *Stop* icon is pressed.
- It can let a continuously active signal from a product detect sensor, keep continuous printing active. Printing will continue, until the product detect sensor signal stops.

To setup continuous print trigger mode:

1. From the *Home* screen, select the *Settings* icon:



2. Select the *System Settings* icon:



3. Set *Print trigger* to *Continuous*.

4. Choose the *Sensor mode*:

Internal	Use the product detect sensor that is built into the printhead to trigger printing.
External	Use an external product detect sensor that is connected to the IO socket to trigger printing.

5. Choose the *Continuous mode*:

Immediately	Print continuously, as soon as the start icon on the home screen is pressed. Printing will stop when the stop icon is pressed. When this mode is selected, a product detect sensor is not needed.
Level	Print continuously, when the printer receives a continuously active signal from a product detect sensor. When the product detect sensor signal stops, printing will stop.
First trigger	Use a product detect sensor signal to trigger the first print of a production line run. Printing will remain continuous after the first product detect sensor signal. Press to stop icon on the home screen to stop printing.

6. If *Continuous mode* is set to *Level*, choose the *Level mode*:

Ignore data	Continuously print the same data from the first print when the sensor is held active. New data will be ignored.
Keep data	Print new data in each label when the sensor is active.

Print Trigger - Sensor

Sensor print trigger mode can be setup in 2 different ways:

- Use the product detect sensor that is built into the printhead, to trigger printing.
- Use an external product detect sensor connected to the IO socket, to trigger printing.

A single print trigger can trigger the start of 1, or more than 1 print.

To setup sensor print trigger mode:

1. From the *Home* screen, select the *Settings* icon:



2. Select the *System Settings* icon:



3. Set *Print* trigger to *Sensor*.

4. Choose the *Sensor mode*:

Internal	Use the product detect sensor that is built into the printhead, to trigger printing.
External	Use an external product detect sensor connected to the IO socket, to trigger printing.

5. Set the *Repeat sensor* value. This setting defines the number of times a print will be repeated after each print trigger. For example, if *Repeat sensor* is set to 1, one print will be made after a print trigger. If *Repeat sensor* is set to 2, one print will be made and then the print will be repeated once after a print trigger.

Bi-Direction

Bi-Direction printing lets the the print direction change from "left to right", and then "right to left".

Use the *Forward offset (mm)* setting [5] to set to the printing position for "left to right". See, [Alignment on page 65](#).

Use the *Reverse offset (mm)* setting [6] to be set to the printing position for "right to left". See, [Alignment on page 65](#).

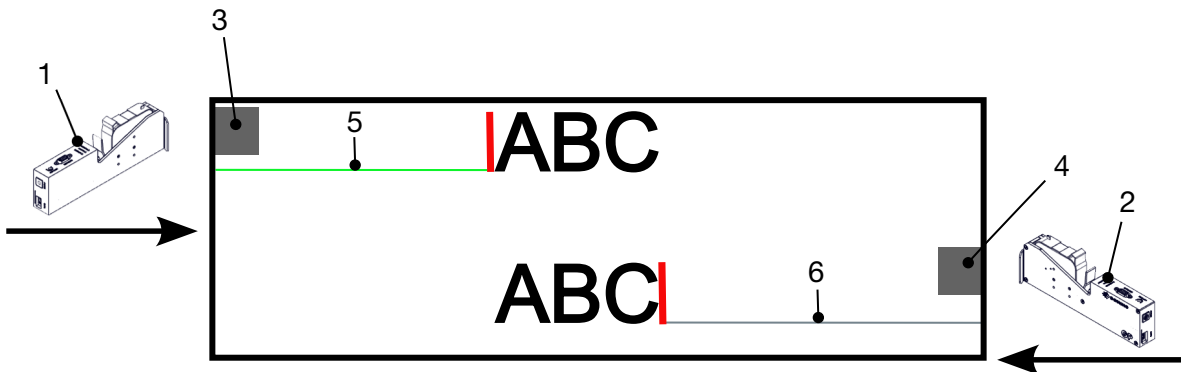

#	Description
1	Printhead/production line direction (Left to Right).
2	Printhead/production line direction (Right to Left).
3	Sensor mark 1
4	Sensor mark 2
5	Forward offset (mm) setting
6	Reverse offset (mm) setting

To enable Bi-Direction mode:

1. From the *Home* screen, select the *Settings* icon:



2. Select the *System Settings* icon:



3. Turn *Bi-Direction* On.



4. Adjust the *Time* value, to set the number of prints that will be made before the print direction changes.

Auto Switch Channel

Note This setting is not available, if *High speed* is enabled.

This setting will automatically change the row of nozzles that is used for printing.

To enable and setup auto switch channel:



1. From the *Home* screen, select the *Settings* icon: 
2. Select the *System Settings* icon: 
3. Turn *Auto switch channel* On
4. Adjust the *Prints per channel* value, to set how many prints will be made using 1 side before switching to the other side (Range: 2-255).

High Speed

Note Enabling this setting will disable *Auto switch channel*.

High speed lets the printer print at high speed resolution. When this setting is enabled, the printing speed can be doubled compared to normal resolution.

To enable high speed:

1. From the *Home* screen, select the *Settings* icon: 
2. Select the *System Settings* icon: 
3. Turn *High speed* On.

Print Static Image

Printing performance can be improved by printing the label template as a static image.

To enable print static image:

1. From the *Home* screen, select the *Settings* icon:



2. Select the *System Settings* icon:



3. Turn *Print static image* On.

Skew Angle

The print can be skewed to a specific angle. This lets the printhead be installed at angles that are not exactly 90° to the print surface.

To enable and adjust the skew angle:

1. From the *Home* screen, select the *Settings* icon:



2. Select the *System Settings* icon:



3. Turn *Skew angle* On.
4. Adjust the *Angle(°)* value (Range: -25 to 25).

Auto Jet (Nozzle Purge)

Auto jet is intended for use with fast drying inks and in high temperature or dirty environments. It is designed to prevent ink from drying in the nozzles and causing missing prints, when the production line re-starts after a temporary pause.

When an auto jet purge happens, very small quantities of ink will be ejected out of the cartridge nozzles. Ink may mark items that are close to the printhead.

-
- Notes
1. It is recommended to always enable this function, to make sure printing quality remains high.
 2. The recommended *Timer (s)* value is between 15 and 20 seconds.
 3. The auto jet function will run when printing and not printing.
 4. Auto jet is different from the purge function. Auto jet will automatically purge the nozzles at regular times. Purge is a manual function.
-

To enable and setup auto jet:

1. From the *Home* screen, select the *Settings* icon:



2. Select the *System Settings* icon:





3. Turn *Auto jet* On.
4. Adjust the *Timer (s)* value to set the time between each auto jet purge in seconds.
5. Adjust the *Column count* value to set the number of columns for purging.

Realtime

Enable this setting to encode the label template and send the data to the printhead in real time.

The default reset time value is 1 second. This means the data will be updated every second. The reset time value is set in seconds. The range for this setting is 1 to 60 seconds.

To enable Realtime:

1. From the *Home* screen, select the *Settings* icon: 
2. Select the *System Settings* icon: 
3. Turn *Realtime* On.
4. Adjust the *Reset time (s)* setting to set how often the data will be updated in seconds.

ADVANCED SETTINGS

To view the advanced settings:

1. From the *Home* screen, select the *Settings* icon:



2. Select the *Advanced Settings* icon:



Display

To set the display settings:

1. From the *Home* screen, select the *Settings* icon:



2. Select the *Advanced Settings* icon:



3. Turn the settings described below On or Off:

Setting Name	Description
Remember printing	If this setting is enabled, when printing starts, the previous label template will be used and any counters will continue from their previous value.
Show printing data	If this setting is enabled, data that has been printed from a database will be shown on the home screen.
Live preview	If this setting is enabled, a preview image of the print will be shown on the home screen.

User Mode (Security)

Enable this feature, to force users to login to the printer with a username and password.

When this feature is enabled, an administrator level user can:

- Create new users
- Edit user permissions & passwords
- Lock users
- Delete users.

To enable user mode:

1. From the *Home* screen, select the *Settings* icon:



2. Select the *Advanced Settings* icon:



3. Turn *User mode* On.
4. Restart the printer.
5. When the printer boots up, use the default administrator username and password below to login:

Username:	Administrator
Password:	admin@2021

Change Password

All users can change their own password, when the user is logged in.

If a password is forgotten, Admin level users can change the password of other users. See [Edit User on page 79](#).

If the Admin level password is forgotten, contact your local Domino support office to unlock the printer.

To change the password of the logged in user:

1. From the *Home* screen, select the *User* icon:



2. Select *Change password*.
3. Enter the current password.
4. Enter a new password.
5. Confirm the new password.
6. Select *OK*.

Log Out

To logout:

1. Select the username in the bottom right corner of the user interface.
2. Select *Logout*.
3. Select *Yes*.

Create User

If user mode is enabled, an Admin level user can create new users.

To create a new user:

1. Login as an Admin level user.

2. From the *Home* screen, select the *User* icon:



3. Select the *User & Permission* tab.

4. Select the *Create user* icon:



5. Adjust the settings listed below:

Name	Description
Username	Enter the new users name. <ul style="list-style-type: none"> • The name must start with a letter • Name length: 6 to 100 characters • Valid characters: Alphanumeric characters and the full stop (period) symbol.
User level	Select the user level: <ul style="list-style-type: none"> • Admin • Supervisor • Technical • Operator.
Password	Enter the new user's password.
Confirm password	Confirm the new user's password.
Permissions	View the tasks that the new user is allowed to do. To change the user's permissions, change the <i>User level</i> setting.

6. Select *Create*.

Edit User

If user mode is enabled, an Admin level user can edit user's accounts.

To edit a user:

1. Login as an Admin level user.

2. From the *Home* screen, select the *User* icon:



3. Select the *User & Permission* tab.

4. Select the *Edit user* icon:



5. Adjust the settings listed below:

Name	Description
User level	Select the user level: <ul style="list-style-type: none"> • Admin • Supervisor • Technical • Operator.
Change password	Show the <i>Password</i> and <i>Confirm password</i> settings.
Password	Change user's password.
Confirm password	Confirm the user's new password.
Permissions	View the tasks that the user is allowed to do. To change the user's permissions, change the <i>User level</i> setting.

6. Select *Save*.

Lock User

If user mode is enabled, an Admin level user can lock/unlock other user accounts. If a user account is locked, the user will not be able to login, until an Admin level user unlocks the account.

To lock/unlock a user:

1. Login as an Admin level user.

2. From the *Home* screen, select the *User* icon:



3. Select the *User & Permission* tab.

4. Select an icon to lock or unlock the user:

	The user is locked. Select to unlock the user.
	The user is unlocked. Select to lock the user.

5. Select *OK*.

Delete User

If user mode is enabled, an Admin level user can delete other users.

To delete a user:

1. Login as an Admin level user.

2. From the *Home* screen, select the *User* icon:



3. Select the *User & Permission* tab.

4. Select the *Delete user* icon:





5. Select *Yes*.

Remote

This setting lets users connect to the printer remotely from the web browser of a PC, laptop, tablet or mobile device (smart phone).

To enable remote:

1. From the *Home* screen, select the *Settings* icon: 
2. Select the *Advanced Settings* icon: 
3. Turn *Remote* On.
4. After this setting is enabled, setup the printer's network settings, see [Network Settings on page 94](#).

High Quality

When enabled, this setting will increase the darkness of the printed label by 30%.

To enable high quality:

1. From the *Home* screen, select the *Settings* icon:



2. Select the *Advanced Settings* icon:



3. Turn *High quality* On.

IO Signal

Enable this function, to adjust the pulse width of the output signal that is sent after printing is done.

When the output is not active, the signal is high (24 V).

When the output is active, the signal is low (0 V).

The IO signal pulse width is illustrated in the diagram below:

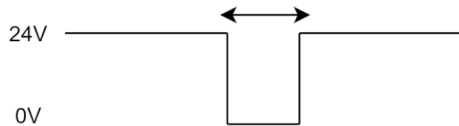

To enable IO signal and adjust the output pulse width:

1. From the *Home* screen, select the *Settings* icon:



2. Select the *Advanced Settings* icon:



3. Turn *IO signal* On.

4. Adjust the *Output Pulse width (ms)* value, to set the width of the output in milliseconds.

Backup and Restore

The printer's settings can be backed up to and restored from a USB memory device.

It is also possible to restore the printer to its factory default settings.

To use the backup and restore settings:

1. From the *Home* screen, select the *Settings* icon:



2. Select the *Advanced Settings* icon:



3. Select one of the options described in the table below:

Setting	Description
Backup	<p>Note Connect a USB memory device before selecting this option.</p> <p>Backup the printer's settings to a connected USB memory device.</p>
Restore	<p>Note Connect a USB memory device that has the restore file saved before selecting this option.</p> <p>Restore the printer's settings from a connected USB memory device.</p>
Reset factory defaults	Reset the printer to the factory default settings.

Common

Common settings configure the printer's language, keyboard layout and clock. Common settings also include configuration for some basic defaults used when making a label template.

To setup the common settings:

1. From the *Home* screen, select the *Settings* icon:



2. Select the *Advanced Settings* icon:



3. Adjust the settings listed below:

Name	Description
Font name	Set the default font for label template objects.
Font size	Set the default font size for label template objects.
Unit	Set the default measurement unit system: <ul style="list-style-type: none"> • Millimeter • Centimeter • Inch.
Primary currency	Set the default currency.
Language	Set the user interface language.
Region	Set the date/time language region.
Standard digits	Set the counter font type: <ul style="list-style-type: none"> • Latin • Arabic
Keyboard layout	Set the keyboard type for the label template designer.
Date	Set the system date and time.
Time zone	Set the system time zone.
Synchronise clock	Note To use this feature, the printer must be connected to the internet. Synchronise the system clock with an internet time server.

Configuring Print Controls

When a printer alert occurs, the printer can react in 1 of three different ways:

- Trigger a warning
- Stop printing
- Be ignored (ignore the alert).

The user can choose how the printer will react to each alert by adjusting the configuring print controls settings.

To setup configuring print controls:

1. From the *Home* screen, select the *Settings* icon:



2. Select the *Advanced Settings* icon:



3. Select *Configuring print controls*.
4. Set the actions for the items listed below:

Name	Description
Speed limit	Select what will happen when the production line speed goes higher than the printer's maximum speed limit.
Receiving data timeout	Select what will happen, if the printer does not receive VDC (variable data connection) data within a specific time.
Delay data	Select what will happen when a print trigger occurs when printing.
Empty data	Select what will happen, if a print is triggered, but the printer has not received variable data.
No cartridge	Select what will happen when there is no ink cartridge in the printhead.
Invalid cartridge	Select what will happen if the ink cartridge is invalid.
Lock cartridges	Select what will happen if the ink cartridge is locked..
Ink out	Select what will happen if the ink cartridge is empty.
Ink low	Select what will happen if the ink level is low.

VDC SETTINGS

To view the VDC (variable data connection) settings:

1. From the *Home* screen, select the *Settings* icon:



2. Select the *VDC Settings* icon:



VDC (Variable Data Connection)

VDC (variable data capture) enables pre-defined parts of a label (database objects and dynamic graphics objects) to be populated with data sent from an external device. Data is stored in a buffer queue within the printer's memory in advance of printing.

If printing stops when VDC is in use, the printer's data buffer queue will be emptied. Data will need to be transmitted to the printer again.

Data can be sent to the printer via 1 of the methods listed below:

- TCP/IP
- COM (RS485)
- INPUT
- Barcode Scanner (Connected via USB)

-
- Notes
1. To create a text object that uses VDC data in the label, see [VDC Database Text Object on page 120](#).
 2. To create a graphics object that uses VDC data in the label, see [VDC Dynamic Graphics Object on page 135](#).
-

To enable and setup VDC:

1. From the *Home* screen, select the *Settings* icon:



2. Select the *VDC Settings* icon:



3. Turn *VDC* On.

4. Adjust the settings listed below:

Name	Description
Mode	<p>Select what action will occur when the printer receives data:</p> <ul style="list-style-type: none"> • <i>Print all</i> - Print all messages from the sender. After the last message is printed, the printer will go to a "NO DATA" state and wait for new data. If the product detect sensor is triggered when there is no data, the printer will stop and show an error. • <i>Print last</i> - Only print the last message from the sender. • <i>Print last and repeat</i> - Only print the last message from the sender and continue to print the last message until new messages are received.
Data type	<p>Select the VDC data type:</p> <ul style="list-style-type: none"> • JSON • Raw data • Customize.
Connection	<p>Select the connection method:</p> <ul style="list-style-type: none"> • TCP/IP • COM (RS485) • INPUT • Barcode scanner (connected via USB).
Response VDC Data	<p>Turn this function On, to send a response to the sender when VDC data is printed.</p>
Response VDC Command	<p>Turn this function On, to send a response to the sender when VDC data is received.</p>
Controller port	<p>Note This setting is only valid if <i>Connection</i> is set to <i>TCP/IP</i>.</p> <p>Select the printer's communication port. Default: 2030</p>
COM Port	<p>Note This setting is only valid if <i>Connection</i> is set to <i>COM</i>.</p> <p>Select the printer's communication port. Default: COM0</p>

INSTALLATION

Name	Description
Data bits	<p>Note This setting is only valid if <i>Connection</i> is set to <i>COM</i>.</p> <p>Select the number of data bits in each character:</p> <ul style="list-style-type: none"> • 4 • 5 • 6 • 7 • 8.
Parity	<p>Note This setting is only valid if <i>Connection</i> is set to <i>COM</i>.</p> <p>Select the type of parity bit that will be expected.</p> <p>A parity bit is an extra data bit that will be sent with each data character to detect errors in the transmission:</p> <ul style="list-style-type: none"> • None - No parity will be expected • Even - The parity bit will always be even • Mark- The parity bit will always be 1 • Odd - The parity bit will always be odd • Space - The parity bit will always be 0.
Baud rate	<p>Note This setting is only valid if <i>Connection</i> is set to <i>COM</i>.</p> <p>Select the baud rate between the printer and the device that the printer is connected to:</p> <ul style="list-style-type: none"> • 9600 • 19200 • 38400 • 57600 • 115200.
Stop bits	<p>Note This setting is only valid if <i>Connection</i> is set to <i>COM</i>.</p> <p>Select the number of stop bits that will be sent at the end of each character to enable the detection of the end of the character:</p> <p>1, or 2.</p>

Rule

The rule settings define how incoming data is treated. The available settings are different depending on the selected data type.

Rule Settings for JSON Data

To setup rule for Json or Raw data:

1. From the *Home* screen, select the *Settings* icon:



2. Select the *VDC Settings* icon:



3. Set *Data type* to *Json* or *Raw*.
4. Scroll down to the *Rule* settings.
5. Adjust the settings listed below:

Name	Description
Split character	Choose the character that is used to separate each item of data in the data package.
Encoding	Choose the encoding mode of the data package.

Rule Settings for Customize Data

For the customize data type, the rule settings define what part of the data package will be printed.

Data can be selected for printing by choosing which numerical bytes of data from the data package will be printed. Or, characters can be used to mark the start and end of printable data.

Bytes of Data

To setup *Rule* using the *Bytes of data* option when *Data type* is *Customize*:

1. From the *Home* screen, select the *Settings* icon:



2. Select the *VDC Settings* icon:



3. Set *Data type* to *Customize*.
4. Scroll down to the *Rule* settings.
5. Select *Configurations*.
6. Set *Get data type* to *Bytes of data*.
7. Set *Package length* to the number of bytes in the data package. If the data package is shorter/longer than this length, the data will not be accepted. For example, in the data package below, *Package length* should be set to 16:

Data:	S	T	\$	A	B	#	8	.	6	k	g	\$	C	D	E	N
Byte #:	0	1	2	3	4	5	6	7	8	9	10	11	12	13	14	15

8. Use the *VDC field* options, to set how many variable data objects will be printed in the label. For example, if the label will contain 1 variable data objects, tick *VDC1*.
9. Use the *Start bytes* and *End bytes* settings to choose the first and last bytes of the data package to be printed. In the data package example below, to print "8.6kg", set *Start bytes* to 6 and *End bytes* to 10:

Data:	S	T	\$	A	B	#	8	.	6	k	g	\$	C	D	E	N
Byte #:	0	1	2	3	4	5	6	7	8	9	10	11	12	13	14	15

Characters

To setup *Rule* using the *Characters* option when *Data type* is *Customize*:

1. From the *Home* screen, select the *Settings* icon:



2. Select the *VDC Settings* icon:



3. Set *Data type* to *Customize*.
4. Scroll down to the *Rule* settings.
5. Select *Configurations*.
6. Set *Get data type* to *Characters*.
7. Set *Package length* to the number of bytes in the data package. If the data package is shorter/longer than this length, the data will not be accepted. For example, in the data package below, *Package length* should be set to 16:

Data:	S	T	\$	A	B	#	8	.	6	k	g	\$	C	D	E	N
Byte #:	0	1	2	3	4	5	6	7	8	9	10	11	12	13	14	15

8. The *Prefix* setting can be used to set the characters that mark the start of the data package. For example, in the data package below, *Prefix* should be set to *ST*:

Data:	S	T	\$	A	B	#	8	.	6	k	g	\$	C	D	E	N
Byte #:	0	1	2	3	4	5	6	7	8	9	10	11	12	13	14	15

9. The *Suffix* setting can be used to set the characters that mark the end of the data package. For example, in the data package below, *Suffix* should be set to *EN*:

Data:	S	T	\$	A	B	#	8	.	6	k	g	\$	C	D	E	N
Byte #:	0	1	2	3	4	5	6	7	8	9	10	11	12	13	14	15

10. Use the *VDC field* options, to set how many variable data objects will be printed in the label. For example, if the label will contain 1 variable data object, only tick *VDC1*.
11. Use the *Start characters* and *End characters* settings to define the start and end of printable data. In the data package example below, to print "8.6kg", set *Start characters* to *\$AB#* and *End characters* to *\$CD*:

Data:	S	T	\$	A	B	#	8	.	6	k	g	\$	C	D	E	N
Byte #:	0	1	2	3	4	5	6	7	8	9	10	11	12	13	14	15

Monitor

When using VDC, this function lets the user get real time printer information such as speed, printer status, printed pages, printhead status etc.

To enable and setup monitor:

1. From the *Home* screen, select the *Settings* icon:



2. Select the *VDC Settings* icon:



3. Turn *Monitor* On.
4. Adjust the settings listed below:

Name	Description
Response	Select how the printer will respond to printer status requests: <ul style="list-style-type: none"> • <i>Time interval</i> - Respond to status requests within a user specified period of time. • <i>Each print</i> - Respond to status requests after each print.
Interval length (s)	If <i>Response</i> is set to <i>Time interval</i> , set the period of time allowed for the printer to respond to the status request.

NETWORK SETTINGS

The printer can be controlled through the network by the web browser of a PC, laptop or tablet or mobile device (smart phone). To do this, make sure the remote setting is enabled, see [Remote on page 81](#).

To view the network settings:

1. From the *Home* screen, select the *Settings* icon:



2. Select the *Network Settings* icon:



IP Address

To setup the printer's IP address:

1. From the *Home* screen, select the *Settings* icon:



2. Select the *Network Settings* icon:



3. Adjust the settings listed below:

Name	Description
Dynamic	Select if the printer will automatically obtain an IP address from the connected network, or use a static IP address: <ul style="list-style-type: none"> • <i>On</i> - Automatically obtain an IP address from the network. • <i>Off</i> - Set a static IP address.
IP	The IP address of the printer: <ul style="list-style-type: none"> • If <i>Dynamic</i> is <i>Off</i>, get an IP address from the network administrator. • Make sure that the IP address is in the same range as other devices on the network. • Make sure the address does not conflict with any other device on the network.
Subnet mask	Set the subnet mask. The subnet mask must match other devices on the same network. Default: 255.255.255.0
Default gateway	If the printer needs to communicate with devices on a different network (or the internet), enter the IP address of the network's default gateway (router).

4. Select *Save*.

DNS Server Address

To setup the DNS (domain name system) server address:

1. From the *Home* screen, select the *Settings* icon:



2. Select the *Network Settings* icon:



3. Adjust the settings listed below:

Name	Description
Dynamic	Select if the printer will automatically obtain an IP address from the connected network or use a static IP address: <ul style="list-style-type: none"> • <i>On</i> - Automatically obtain an IP address from the network. • <i>Off</i> - Set a static IP address.
Preferred DNS server	Enter the preferred DNS server address.
Alternate DNS server	Enter an alternate DNS server address.

4. Select *Save*.

Control the Printer via Web Browser

To control the printer via web browser:

1. Connect an Ethernet cable from the network to the printer's Ethernet socket.

2. From the *Home* screen, select the *Settings* icon:



3. Select the *Advanced Settings* icon:



4. Turn *Remote* On.

5. Select the *Network Settings* icon:



6. Setup the printer's network settings, see [IP Address on page 94](#).

7. Open a web browser on a PC, laptop, tablet or mobile device (smart phone) that is also connected to the network.

8. Enter the IP address of the printer followed by ":8080" into the address bar, for example:



9. If the connections fails, turn the *Remote* setting off/on, and re-boot the printer.

POWER SAVE SETTINGS

To view the power save settings:

1. From the *Home* screen, select the *Settings* icon:



2. Select the *Power Save Settings* icon:



Monitor

To view and edit the power save monitor settings:

1. From the *Home* screen, select the *Settings* icon:



2. Select the *Power Save Settings* icon:



3. Adjust the settings listed below:

Name	Description
Brightness	Use the slider bar to adjust the screen brightness.
Power save	Turn power save settings <i>On</i> or <i>Off</i> . When enabled, the <i>Darken screen</i> and <i>Turn off screen</i> settings will be available.
Darken screen	<p>After a set time of no action, the screen will darken to save power.</p> <p>The screen will darken by 50%.</p> <p>The screen will go back to the set brightness value when touched.</p> <p>The available settings are:</p> <ul style="list-style-type: none"> • 30 seconds • 1 minute • 5 minutes • Never
Turn off screen	<p>After a set time of no action, the screen will turn off to save power.</p> <p>The screen will go back to the set brightness value when touched.</p> <p>The available settings are:</p> <ul style="list-style-type: none"> • 10 minutes • 30 minutes • 1 hour • Never

LANGUAGE SETTINGS

To view and edit the language settings:

1. From the *Home* screen, select the *Settings* icon:



2. Select the *Language Settings* icon:



Import Language

To import a new language:

1. Put the language file into the top level (root folder) of a USB memory device.
2. Connect the USB memory device to the printer.

3. From the *Home* screen, select the *Settings* icon:



4. Select the *Language Settings* icon:



5. Select the *Import* icon:



6. Select the language file.
7. Select *OK* and wait for the file to import.

Export Language

To export a language from the printer:

1. Connect a USB memory device to the printer.

2. From the *Home* screen, select the *Settings* icon:



3. Select the *Language Settings* icon:



4. Select the *Export* icon:



5. Select the language file.
6. Choose a folder to save the language file to.
7. Select *OK* and wait for the file to export.

Delete Language

To delete a language from the printer:

1. From the *Home* screen, select the *Settings* icon:



2. Select the *Language Settings* icon:



3. Select the *Delete* icon for the language to be deleted:



FONT SETTINGS

To view and edit the font settings:

1. From the *Home* screen, select the *Settings* icon:



2. Select the *Font Settings* icon:



Import Font

To import a new font:

1. Put the font file into the top level (root folder) of a USB memory device.
2. Connect the USB memory device to the printer.

3. From the *Home* screen, select the *Settings* icon:



4. Select the *Font Settings* icon:



5. Select the *Import* icon:



6. Select the font file.

Delete Font

To delete a font:

1. From the *Home* screen, select the *Settings* icon:



2. Select the *Font Settings* icon:



3. Select the *Delete* icon for the font to be deleted:



PART 4 OPERATION

START UP

WARNING

Hazardous Chemicals. Risk of eye and skin damage.



Wear protective equipment such as gloves and glasses when near the printer.

Contact with chemicals can cause skin or eye damage.
Refer to Safety Data Sheet.

CAUTION

Fragile Electrical Contacts. Risk of Equipment Damage.



Do not force the cartridge into the printhead.

Be careful when inserting the cartridge. Forcing the cartridge against the electrical contacts can break the contacts on the printhead circuit board.

To start up the printer:

1. Remove the protective cover from the ink cartridge.
2. If the cartridge is new, clean the electrical contacts with an ethanol wipe, to remove corrosion protection.

Note Cleaning wipe part number: EPT039697

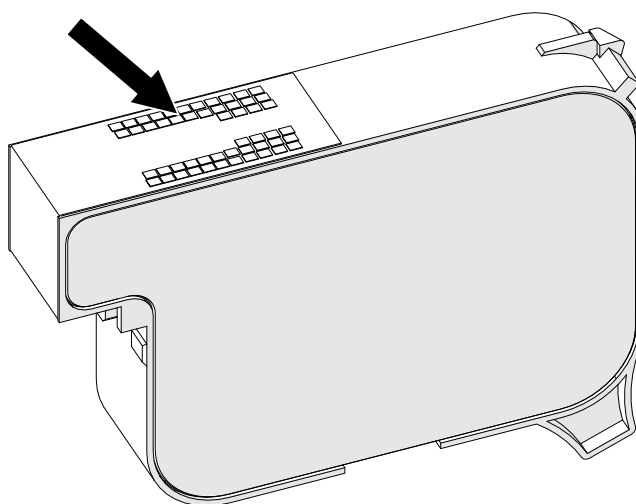

3. Use a new/clean lint-free cloth to wipe the ink cartridge nozzles at a 45° angle.

Note The 45° angle stops debris from one nozzle contaminating the next nozzle.

CAUTION Sensitive Equipment. Risk of Equipment Damage.



Do not use an ethanol wipe or any other chemical to clean the cartridge nozzles.

Use a new/clean lint-free cloth. If chemicals are used to clean the cartridge, the nozzles may be damaged.

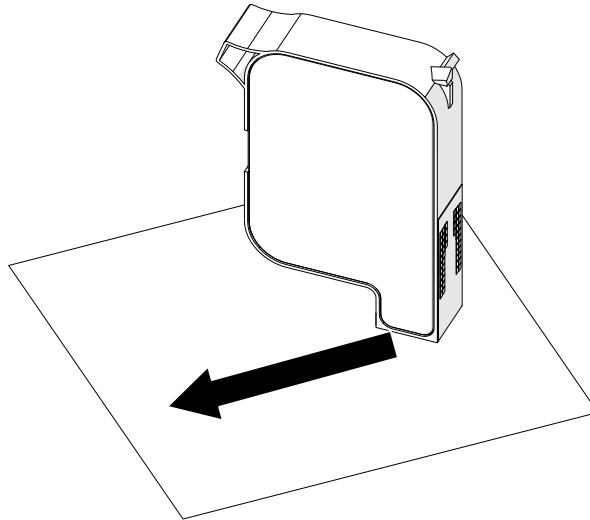

4. Insert the ink cartridge into the printhead and close the printhead latch.

CAUTION Fragile Electrical Contacts. Risk of Equipment Damage.



Do not force the cartridge into the printhead.

Be careful when inserting the cartridge. Forcing the cartridge against the electrical contacts can break the contacts on the printhead circuit board.

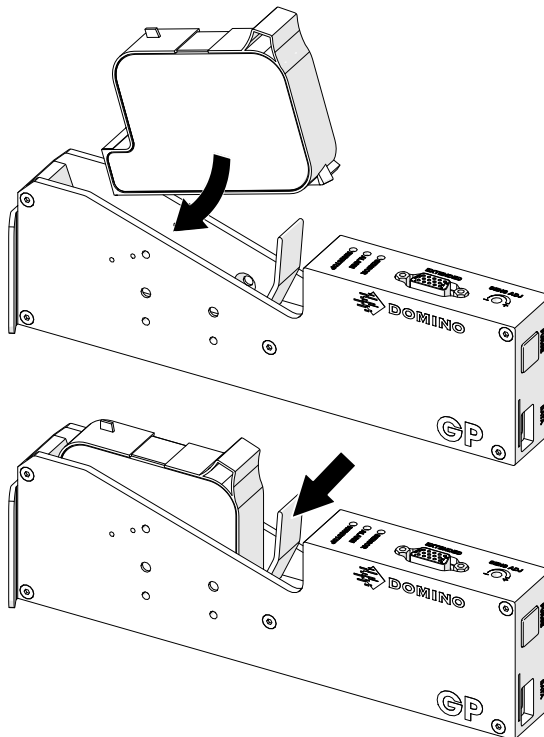

OPERATION

5. Press the *Standby* button shown below and wait for the printer to boot up.

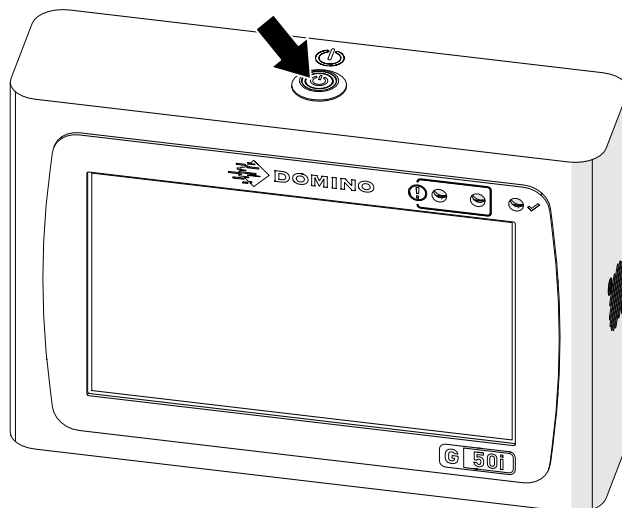

LOAD A LABEL TO PRINT

To load a label to print:

1. From the home screen, select the *Folder* icon:
2. Select the label template to load.



Note A preview of the template will be displayed.

3. Select *Open*.

START PRINTING

To start printing, select the start icon:



STOP PRINTING

Note If printing stops when VDC is in use, the printer's data buffer queue will be emptied. Data will need to be transmitted to the printer again.

To stop printing, select the stop icon:



SHUT DOWN

WARNING

Hazardous Chemicals. Risk of eye and skin damage.



Wear protective equipment such as gloves and glasses when near the printer.

Contact with chemicals can cause skin or eye damage.
Refer to Safety Data Sheet.

To shut down the printer:

1. From the home screen, select the *Standby* icon  and select *Shut down*. Or, press and hold the *Standby* button shown below for 2 seconds.

Note Selecting the *Standby* icon or pressing the *Standby* button does not disconnect the printer from the electrical power supply.

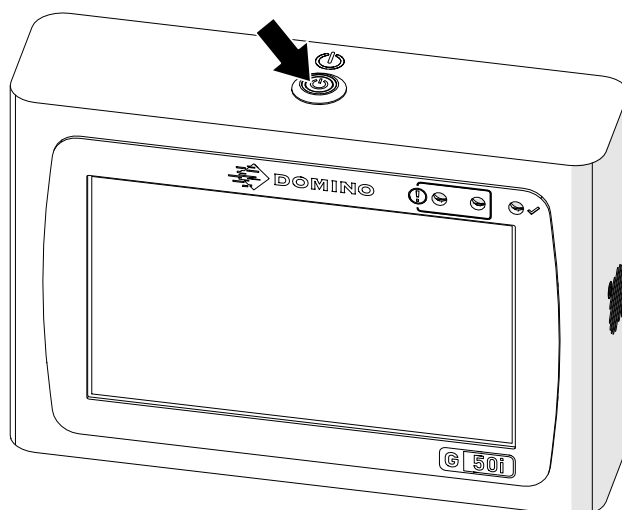

OPERATION

2. Open the latch and remove the ink cartridge.

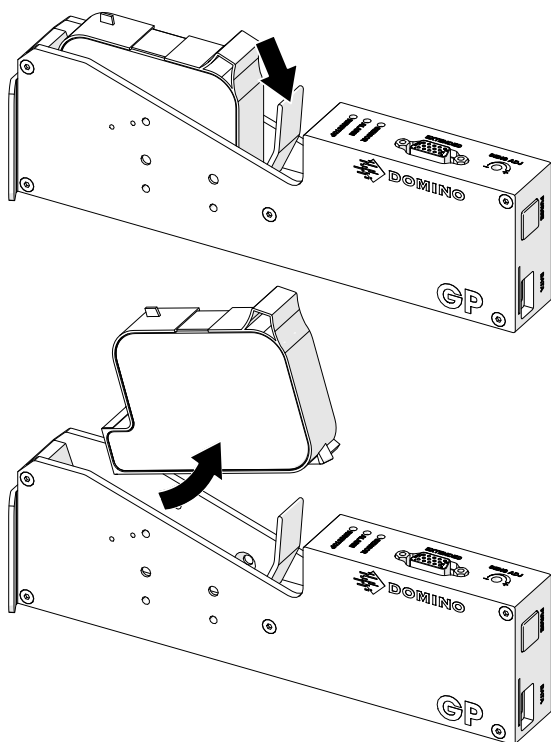

3. Fit the protective cover to the cartridge, to prevent the cartridge nozzles from drying.





ADD OBJECTS TO LABEL TEMPLATE

Add a Text Object

To add a text object to the label template:

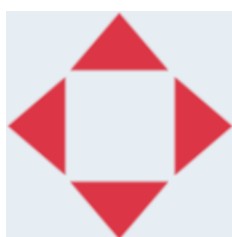
1. Select the *Object* icon: 
2. Select *Text*.
3. Input the required text.
4. Select *OK*.
5. Drag the object to a suitable location in the template, or use the arrow icons to reposition the object:



6. To change the object's appearance, select the properties icon: 

Note The properties icon is not used, if the web browser interface is being used.

7. In the *General* tab, use the settings listed below to change the object's general appearance:

Setting Name	Description
X (mm)	Set the horizontal position of the object in the template.
Y (mm)	Set the vertical position of the object in the template.
Width (mm)	Set the width of the object.
Height (mm)	Set the height of the object.
Scale mode	Set the scale mode of the object: <ul style="list-style-type: none"> • Scale - The width and height of the object can be set independently. • Auto size - The width and height of the object is controlled by the font size.
Angle	Rotate the object.
Lock	Lock the object to prevent it from being edited.
Visible	Make the object printable or not printable.
Font family	Set the font type.
Size (pt)	Set the font size.

OPERATION

Setting Name	Description
Style	Choose: <ul style="list-style-type: none"> • Bold • Italic • Underlined.
Text align	If the object has more than 1 line, set the alignment: <ul style="list-style-type: none"> • Left • Center • Right.
Remove blank line	Remove blank lines from the object.
Remove leading space	Remove leading spaces from the object.

8. Open the *Text* tab, to change the text.

Add a Counter Object

To add a counter object to the label template:

1. Select the *Object* icon: 
2. Select *Counter*.
3. Input the object data:

Name	Description
Start value	Set the counter object's start value.
End value	Set the counter object's end value. When the counter reaches this value, it will return to the start value.
Step value	Set the counter object's increment/step value.
Repeat time	Set the number of times each counter value will be repeated.
Prefix	Set a prefix value for the counter object.
Suffix	Set a suffix value for the counter object.
Padding character	Set the number of padding characters (Range: 1 to 10)
Step	Set the counting direction: <ul style="list-style-type: none"> • Up • Down.
Standard digits	Set the type of digit: <ul style="list-style-type: none"> • Latin • Arabic.
Content	Displays a preview of the counter object.

4. Select *OK*.
5. Drag the object to a suitable location in the template, or use the arrow icons to reposition the object:

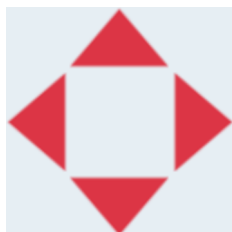

6. To change the object's appearance, select the properties icon: 

Note The properties icon is not used, if the web browser interface is being used.

7. In the *General* tab, use the settings listed below to change the object's general appearance:

Setting Name	Description
X (mm)	Set the horizontal position of the object in the template.
Y (mm)	Set the vertical position of the object in the template.
Width (mm)	Set the width of the object.
Height (mm)	Set the height of the object.
Scale mode	Set the scale mode of the object: <ul style="list-style-type: none"> Scale - The width and height of the object can be set independently. Auto size - The width and height of the object is controlled by the font size.
Angle	Rotate the object.
Lock	Lock the object to prevent it from being edited.
Visible	Make the object printable or not printable.
Font family	Set the font type.
Size (pt)	Set the font size.
Style	Choose: <ul style="list-style-type: none"> Bold Italic Underlined.
Text align	If the object has more than 1 line, set the alignment: <ul style="list-style-type: none"> Left Center Right.
Remove blank line	Remove blank lines from the object.
Remove leading space	Remove leading spaces from the object.

8. In the *Counter* tab, use the settings listed below to change counter object settings:

Name	Description
Start value	Set the counter object's start value.
End value	Set the counter object's end value. When the counter reaches this value, it will return to the start value.
Step value	Set the counter object's increment/step value.
Repeat time	Set the number of times each counter value will be repeated.
Prefix	Set a prefix value for the counter object.
Suffix	Set a suffix value for the counter object.
Padding character	Set the number of padding characters (Range: 1 to 10)

OPERATION

Name	Description
Step	Set the counting direction: <ul style="list-style-type: none"> • Up • Down.
Standard digits	Set the type of digit: <ul style="list-style-type: none"> • Latin • Arabic.
Content	Displays a preview of the counter object.

Add a Database Object

A database object lets a pre-defined part of the label (database object) be populated with data from another source.

2 different types of database object can be created:

- Database - Use a database file saved onto a USB memory device that is connected to the printer.
- VDC (Variable Database Connection) - Use data that is transmitted from an external device via, TCP/IP, COM (RS485), INPUT, or Barcode Scanner (Connected via USB).

Database Text Object

This topic describes how to setup a database object, using a database file saved on a USB memory device.

Valid database file formats:

- .txt
- .csv

To add a database object to the label template:

1. Put the database file onto a USB memory device. The image below is a simple .csv file that will be used as an example:

	A	B	C
1	Number	Letter	
2	001	A	
3	002	B	
4	003	C	
5	004	D	
6	005	E	

2. Connect the USB memory device to the printer.



3. Select the *Object* icon:
4. Select *Database*.
5. Select *Load database*.
6. Set the settings listed below:

Setting Name	Description
File type	Choose the database file type, TXT or CSV.

OPERATION

Setting Name	Description
Encoding	Choose the database file encoding type.
Split char	Choose the character that is used to split items in the database file.
First row header	Choose if the first row of data will be used as a heading to identify data in the user interface. If this setting is enabled, the first row of data will not be printed.

7. Select the *Select file* icon: 

8. Open the D:/ drive: 

9. Choose the database file and select the tick icon.

10. Select *Next*.

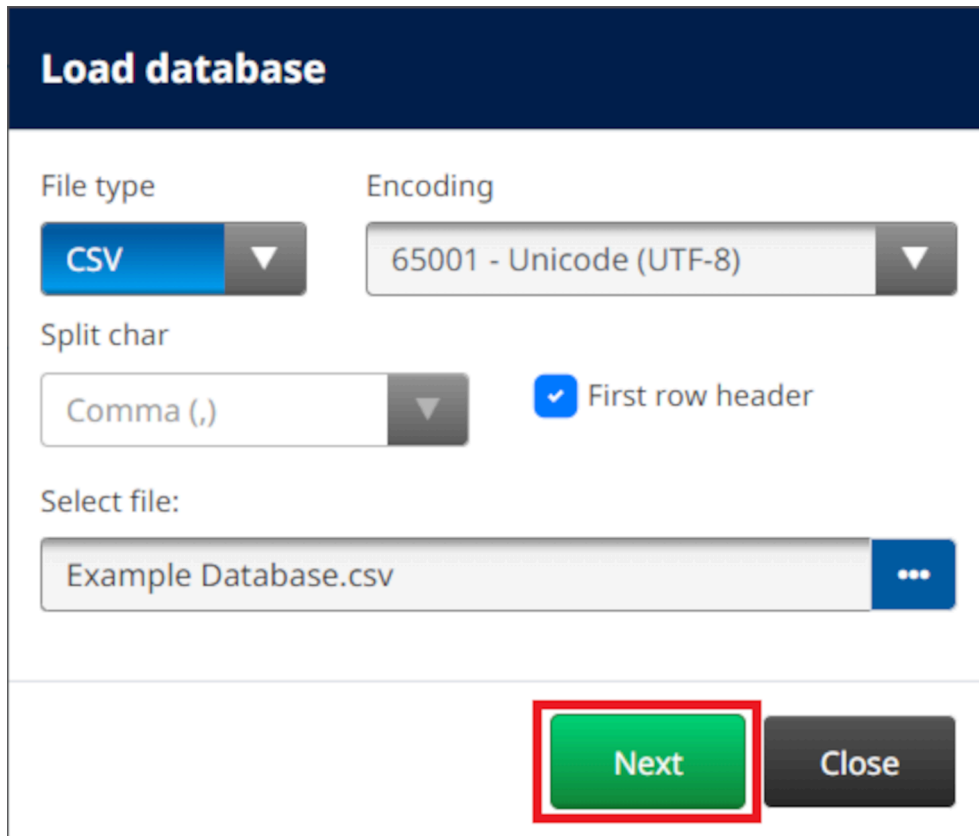

Load database

File type: CSV

Encoding: 65001 - Unicode (UTF-8)

Split char: Comma (,)

First row header

Select file: Example Database.csv

Next Close

11. A list of items in the database will now be displayed, select *OK* to continue.

Load database

Name: Example Database.csv Show: 5/6

#	Number	Letter
1	001	A
2	002	B
3	003	C
4	004	D
5	005	E

Back **OK** Close

12. Use the arrow icons, to move the database fields that will be printed from the *Source* list to the *Destination* list.

Notes 1. Items in the *Source* list will not be printed.

2. In the example below, the database items "Number" and "Letter" will be printed.

Database

Remove source

Source		Destination
Datetime	➤	Number
Counter	➤	Letter
Shiftcode	➤	
Number	➤	
Letter	➤	

Text

001

OK
Close

13. It is also possible to include *Text*, *Datetime*, *Counter* and *Shiftcode* elements within the object. To include one or more of these elements, move them from the *Source* list to the *Destination* list. After moving the required elements to the *Destination* list, select them and adjust the element's settings.
14. Select *OK*.
15. Drag the object to a suitable location in the template, or use the arrow icons to reposition the object:

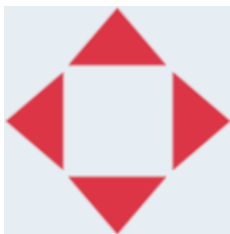

16. To change the object's appearance, select the properties icon:



Note The properties icon is not used, if the web browser interface is being used.

17. In the *General* tab, use the settings listed below to change the object's general appearance:

Setting Name	Description
X (mm)	Set the horizontal position of the object in the template.
Y (mm)	Set the vertical position of the object in the template.
Width (mm)	Set the width of the object.
Height (mm)	Set the height of the object.
Scale mode	Set the scale mode of the object: <ul style="list-style-type: none"> Scale - The width and height of the object can be set independently. Auto size - The width and height of the object is controlled by the font size.
Angle	Rotate the object.
Lock	Lock the object to prevent it from being edited.
Visible	Make the object printable or not printable.
Font family	Set the font type.
Size (pt)	Set the font size.
Style	Choose: <ul style="list-style-type: none"> Bold Italic Underlined.
Text align	If the object has more than 1 line, set the alignment: <ul style="list-style-type: none"> Left Center Right.
Remove blank line	Remove blank lines from the object.
Remove leading space	Remove leading spaces from the object.

18. In the *Database* tab, use the settings listed below to change database object settings:

Name	Description
Remove source	Note This setting is only visible, if a database source is selected. Disconnect the object from the current database source. This lets a new database source be selected.
Load database	Load a database file from a connected USB memory device.
Load VDC	Load and setup a variable database connection source.
Source	This is a list of items that are available to add to the database object. To add an item to the database object, use the arrow icons to move it to the <i>Destination</i> list.

OPERATION

Name	Description
Destination	This is a list of items that have been added to the database object. To remove an item from the database object, use the arrow icons to move it to the <i>Source</i> list.
Content	Displays a preview of the database object.

VDC Database Text Object

This topic describes how to setup a database object, using a variable database connection to another device.

To add a database object to the label template:

1. Setup the connection to the device that will transmit data to the printer, see [VDC Settings on page 87](#).



2. In the label template designer, select the *Object* icon:
3. Select *Database*.
4. Select *Load VDC*.
5. Select *OK*.

Load VDC

Field name

Default field Reset field

List field

VDC1	VDC2	VDC3	VDC4	VDC5
VDC6	VDC7	VDC8	VDC9	VDC10
VDC11	VDC12	VDC13	VDC14	VDC15
VDC16	VDC17	VDC18	VDC19	VDC20

OK Close

6. Use the arrow icons, to move the database fields that will be printed from the *Source* list to the *Destination* list. Up to 20 VDC items can be selected (VDC1 to VDC20).

Notes 1. Items in the *Source* list will not be printed.

2. In the example below, VDC1 and VDC2 will be printed.

Database

Remove source

Source		Destination
Text	➤	VDC1
Datetime	➤	VDC2
Counter	➤	
Shiftcode	➤	
VDC1	➤	

Text

VDC1

OK
Close

7. It is also possible to include *Text*, *Datetime*, *Counter* and *Shiftcode* elements within the object. To include one or more of these elements, move them from the *Source* list to the *Destination* list. After moving the required elements to the *Destination* list, select them and adjust the element's settings.
8. Select *OK*.
9. Drag the object to a suitable location in the template, or use the arrow icons to reposition the object:

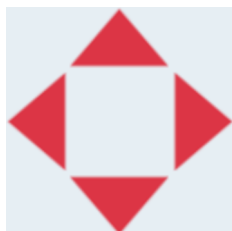

10. To change the object's appearance, select the properties icon:



Note The properties icon is not used, if the web browser interface is being used.

11. In the *General* tab, use the settings listed below to change the object's general appearance:

Setting Name	Description
X (mm)	Set the horizontal position of the object in the template.
Y (mm)	Set the vertical position of the object in the template.
Width (mm)	Set the width of the object.
Height (mm)	Set the height of the object.
Scale mode	Set the scale mode of the object: <ul style="list-style-type: none"> Scale - The width and height of the object can be set independently. Auto size - The width and height of the object is controlled by the font size.
Angle	Rotate the object.
Lock	Lock the object to prevent it from being edited.
Visible	Make the object printable or not printable.
Font family	Set the font type.
Size (pt)	Set the font size.
Style	Choose: <ul style="list-style-type: none"> Bold Italic Underlined.
Text align	If the object has more than 1 line, set the alignment: <ul style="list-style-type: none"> Left Center Right.
Remove blank line	Remove blank lines from the object.
Remove leading space	Remove leading spaces from the object.

12. In the *Database* tab, use the settings listed below to change database object settings:

Name	Description
Remove source	Note This setting is only visible, if a database source is selected. Disconnect the object from the current database source. This lets a new database source be selected.
Load database	Load a database file from a connected USB memory device.
Load VDC	Load and setup a variable database connection source.
Source	This is a list of items that are available to add to the database object. To add an item to the database object, use the arrow icons to move it to the <i>Destination</i> list.

OPERATION

Name	Description
Destination	This is a list of items that have been added to the database object. To remove an item from the database object, use the arrow icons to move it to the <i>Source</i> list.
Content	Displays a preview of the database object.

Populate the VDC Database Text Object with Data

Note If printing stops when VDC is in use, the printer's data buffer queue will be emptied. Data will need to be transmitted to the printer again.

To populate the VDC database object with data:

1. Select the *Save* icon, to save the label template: 

2. From the *Home* screen, select the *Folder* icon: 

3. Select the label template to load.

Note A preview of the template will be displayed.

4. Select *Open*.

5. Select the *Start* icon, to start printing: 

6. Transmit data from the external device to the printer.

7. The data will now be shown at the bottom of the *Home* screen.

Add a Barcode Object

To add a barcode object to the label template:



1. Select the *Object* icon:
2. Select *Barcode*.
3. Input the object data:

Name	Description
Source	Select the barcode data type: <ul style="list-style-type: none"> • Text - The barcode data will be generated from static text. • Counter - The barcode data will be generated from a counter. • Datetime - The barcode data will be generated from a clock. • Shiftcode - The barcode data will be generated from a shiftcode. • Boxlot - The barcode data will be generated from a boxlot counter. • Database - The barcode data will be generated from a database.
Barcode type	Select the barcode type.

4. Select *Next*.
5. Setup the barcode source data:

Source Type	Action
Text	Enter the text that will be used to generate the barcode.
Counter	Setup the counter settings, see Add a Counter Object on page 111 .
Datetime	Setup the clock settings, see Add a Clocks Object on page 139 .
Shiftcode	Setup the shiftcode settings, see Add a Shiftcode Object .
Boxlot	Setup the boxlot counter settings, see Add a Boxlot Object on page 147 .
Database	Setup the database settings, see Add a Database Object .

6. Select *OK*.

OPERATION

7. Drag the object to a suitable location in the template, or use the arrow icons to reposition the object:

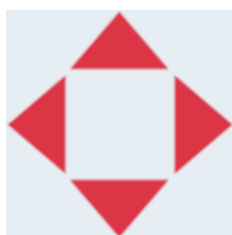

8. To change the object's appearance, select the properties icon:



Note The properties icon is not used, if the web browser interface is being used.

9. In the *General* tab, use the settings listed below to change the object's general appearance:

Setting Name	Description
X (mm)	Set the horizontal position of the object in the template.
Y (mm)	Set the vertical position of the object in the template.
Width (mm)	Set the width of the object.
Height (mm)	Set the height of the object.
Scale mode	Set the scale mode of the object: <ul style="list-style-type: none"> Scale - The width and height of the object can be set independently. Auto size - The width and height of the object is controlled by the font size.
Angle	Rotate the object.
Lock	Lock the object to prevent it from being edited.
Visible	Make the object printable or not printable.
Font family	Set the font type.
Size (pt)	Set the font size.
Style	Choose: <ul style="list-style-type: none"> Bold Italic Underlined.
Text align	If the object has more than 1 line, set the alignment: <ul style="list-style-type: none"> Left Center Right.
Remove blank line	Remove blank lines from the object.
Remove leading space	Remove leading spaces from the object.

10. In the *Barcode* tab, use the settings listed below to change barcode settings.

Name	Description
Name	Name of the selected barcode type.
Module width	Set the barcode module size.
Optimize	Optimise the barcode size.
Encoding mode	Choose the data encoding mode.
Code page	If <i>Encoding mode</i> is set to <i>Code page</i> , choose an encoding method.
Quiet zones	Select the unit of measurement that will be used to define the size of the quiet zone/margin around the barcode: <ul style="list-style-type: none"> • Pixel • Millimeter • Mils • Inch • Percent.
Bar width reduction(%)	Reduce the width of the barcode bars, to compensate for ink spreading out on the print surface.
Left margin	Add a blank space left of the barcode.
Right margin	Add a blank space right of the barcode.
Top margin	Add a blank space above the barcode.
Bottom margin	Add a blank space below the barcode.
Must fit	Choose if the barcode must fit in the bounding rectangle.
Escape sequence	Enable escape sequences in the barcode data such as enter, tab etc.

11. Tabs are also available to change specific settings for the selected barcode type and data source type.

Add a Static Graphics Object

Valid image file formats:

- .jpg
- .bmp
- .png
- .gif

To add a static graphic object to the label template:

1. Connect a USB memory device containing the image file to the printer.

2. Select the *Object* icon: 

3. Select *Graphics*.

4. Set *Image type* as *Static*.

5. Select the *Select image* icon: 

6. Open the D:/ drive: 

7. Choose the image file on the USB memory device and select the tick icon.

8. Select *OK*.

9. Drag the object to a suitable location in the template, or use the arrow icons to reposition the object:

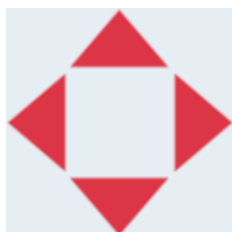

10. To adjust the object's properties, select the properties icon: 

Note The properties icon is not used, if the web browser interface is being used.

11. In the *General* tab, use the settings listed below to change the object's general appearance:

Setting Name	Description
X (mm)	Set the horizontal position of the object in the template.
Y (mm)	Set the vertical position of the object in the template.
Width (mm)	Set the width of the object.
Height (mm)	Set the height of the object.

OPERATION

Setting Name	Description
Scale mode	Set the scale mode of the object: <ul style="list-style-type: none"> • <i>Scale</i> - The width and height of the object can be set independently. • <i>Auto size</i> - The width and height of the object is controlled by the font size.
Angle	Rotate the object.
Lock	Lock the object to prevent it from being edited.
Visible	Make the object printable or not printable.

12. To change the image, select the *Graphics* tab.

Add a Dynamic Graphics Object

A dynamic graphics object lets a pre-defined part of the label (dynamic graphics object) be populated with different images.

Image files are saved on a USB memory device connected to the printer.

Valid image file formats:

- .jpg
- .bmp
- .png
- .gif

2 different types of dynamic graphics object can be created:

- Database - Use a database file saved onto a USB memory device that is connected to the printer, to select the image.
- VDC (Variable Database Connection) - Use data that is transmitted from an external device via, TCP/IP, COM (RS485), or INPUT, to select the image.

Database Dynamic Graphics Object

This topic describes how to setup a dynamic graphics object, that uses a database file saved on a USB memory device, to select the image.

To add a dynamic graphics object to the label template:

1. Save the image files to a folder on a USB memory device.

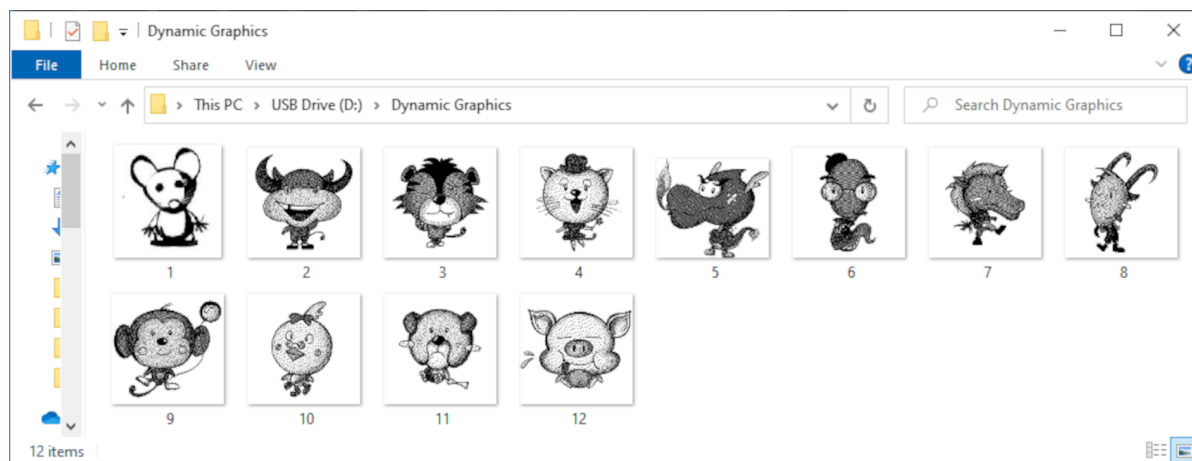

OPERATION

2. Make a .CSV or .TXT file that lists the file names of the images in the order that they will be printed.

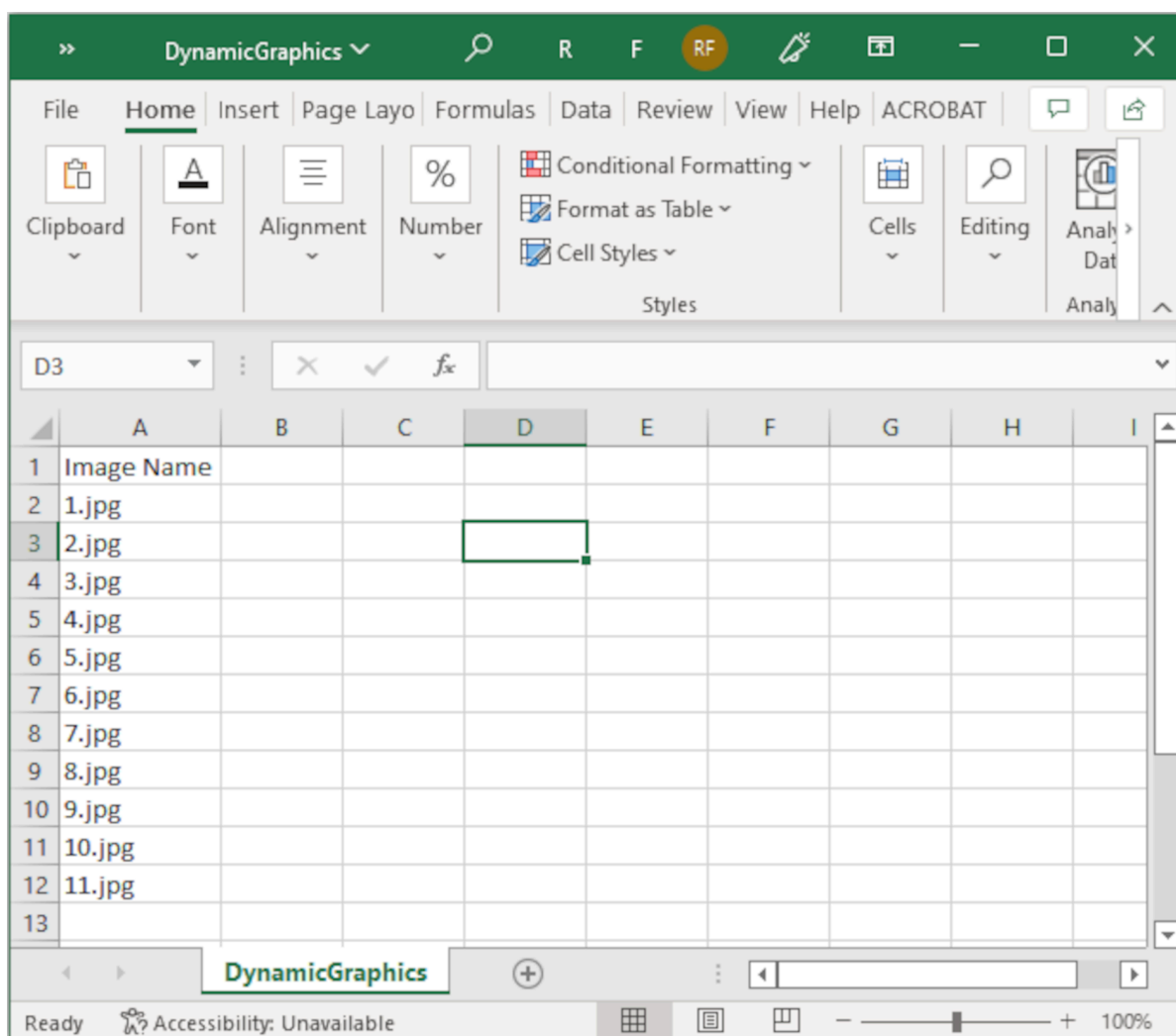

3. Save the .CSV or .TXT file on the same USB memory device that contains the image files.
4. Connect the USB memory device to the printer.
5. Select the *Object* icon: 
6. Select *Graphics*.
7. Set *Image type* as *Dynamic*.
8. Select *Load database*.
9. Set the settings listed below:

Setting Name	Description
File type	Choose the database file type, TXT or CSV.
Encoding	Chose the database file encoding type.
Split char	Choose the character that is used to split items in the database file.

OPERATION

Setting Name	Description
First row header	Choose if the first row of data will be used as a heading to identify data in the user interface. If this setting is enabled, the first row of data will not be used to select an image file.

10. Select the *Select file* icon:



11. Open the D:/ drive:



12. Choose the database file (.CSV or .TXT) on the USB memory device and select the tick icon.

13. Select *Next*.

Load database

File type

CSV
▼

Encoding

65001 - Unicode (UTF-8)
▼

Split char

Comma (,)
▼

First row header

Select file:

DynamicGraphics.csv
...

Next

Close

14. A list of items in the database will now be displayed, select *OK* to continue.

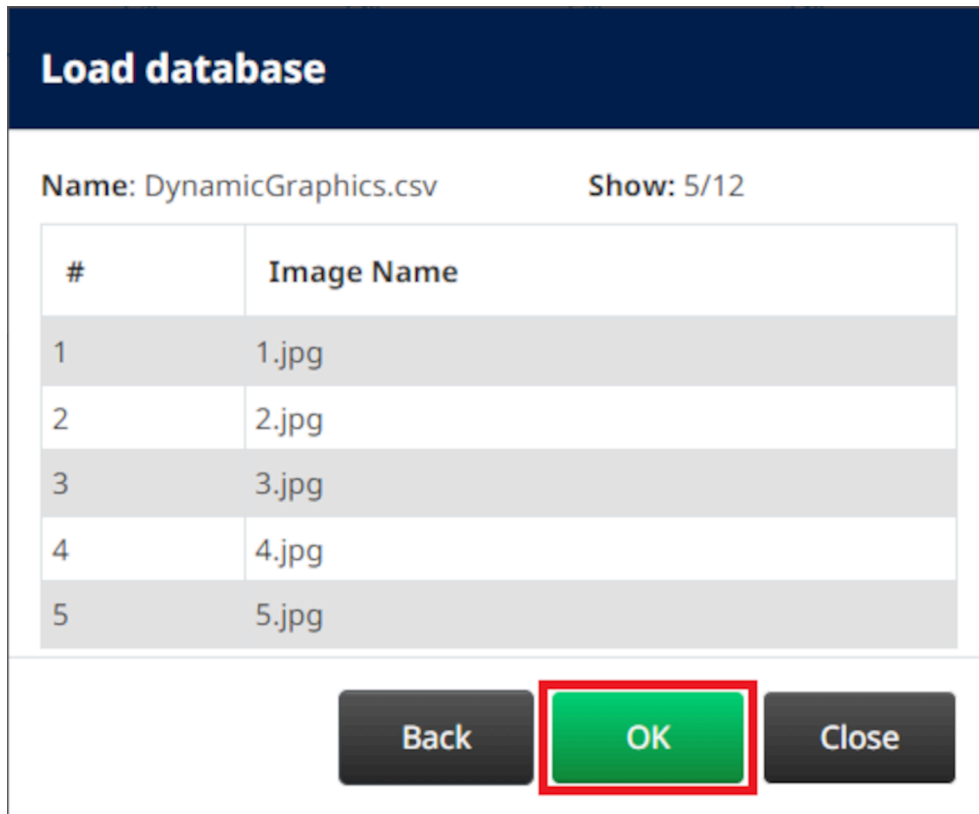

15. Select the *Select folder* icon:



16. Open the D:/ drive:



17. Find the folder that contains the image files, and select the green tick icon.

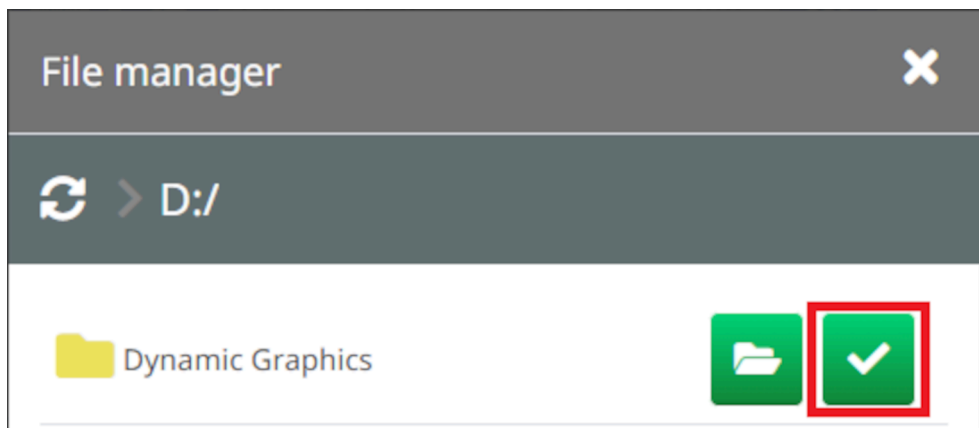

18. Select *OK*.

OPERATION

19. Drag the object to a suitable location in the template, or use the arrow icons to reposition the object:

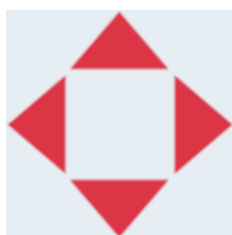

20. To adjust the object's properties, select the properties icon:



Note The properties icon is not used, if the web browser interface is being used.

21. In the *General* tab, use the settings listed below to change the object's general appearance:

Setting Name	Description
X (mm)	Set the horizontal position of the object in the template.
Y (mm)	Set the vertical position of the object in the template.
Width (mm)	Set the width of the object.
Height (mm)	Set the height of the object.
Scale mode	Set the scale mode of the object: <ul style="list-style-type: none">• <i>Scale</i> - The width and height of the object can be set independently.• <i>Auto size</i> - The width and height of the object is controlled by the font size.
Angle	Rotate the object.
Lock	Lock the object to prevent it from being edited.
Visible	Make the object printable or not printable.

22. Select the *Graphics* tab, to change the image database.

VDC Dynamic Graphics Object

This topic describes how to setup a dynamic graphics object, using a variable database connection to another device, to select the image file.

To add a dynamic graphics object to the label template:

1. Setup the connection to the device that will transmit data to the printer, see [VDC Settings on page 87](#).
2. Save the image files to a folder on a USB memory device, and connect it to the printer.

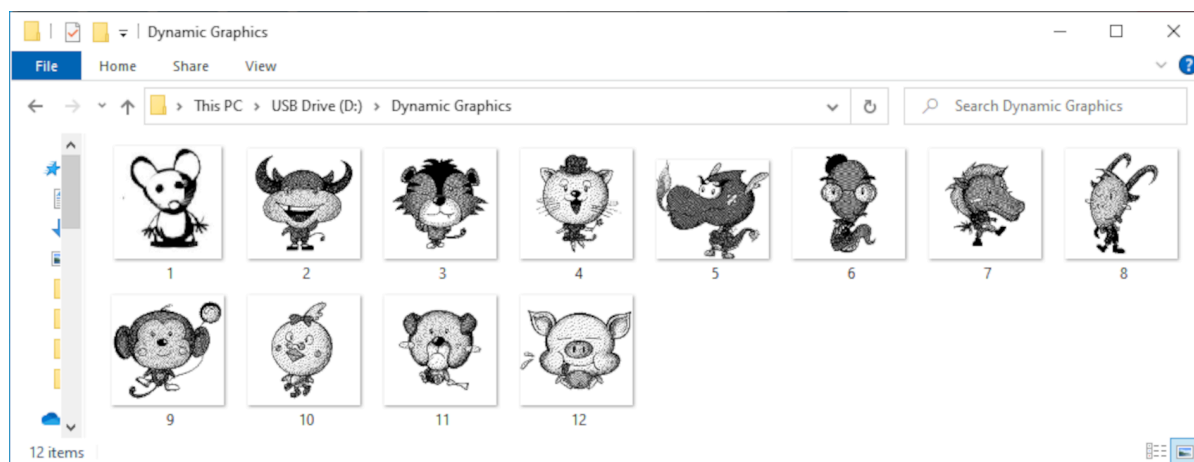

3. In the label template designer, select the *Object* icon: 
4. Select *Graphics > Dynamic > Load VDC*.

5. Select *OK*.

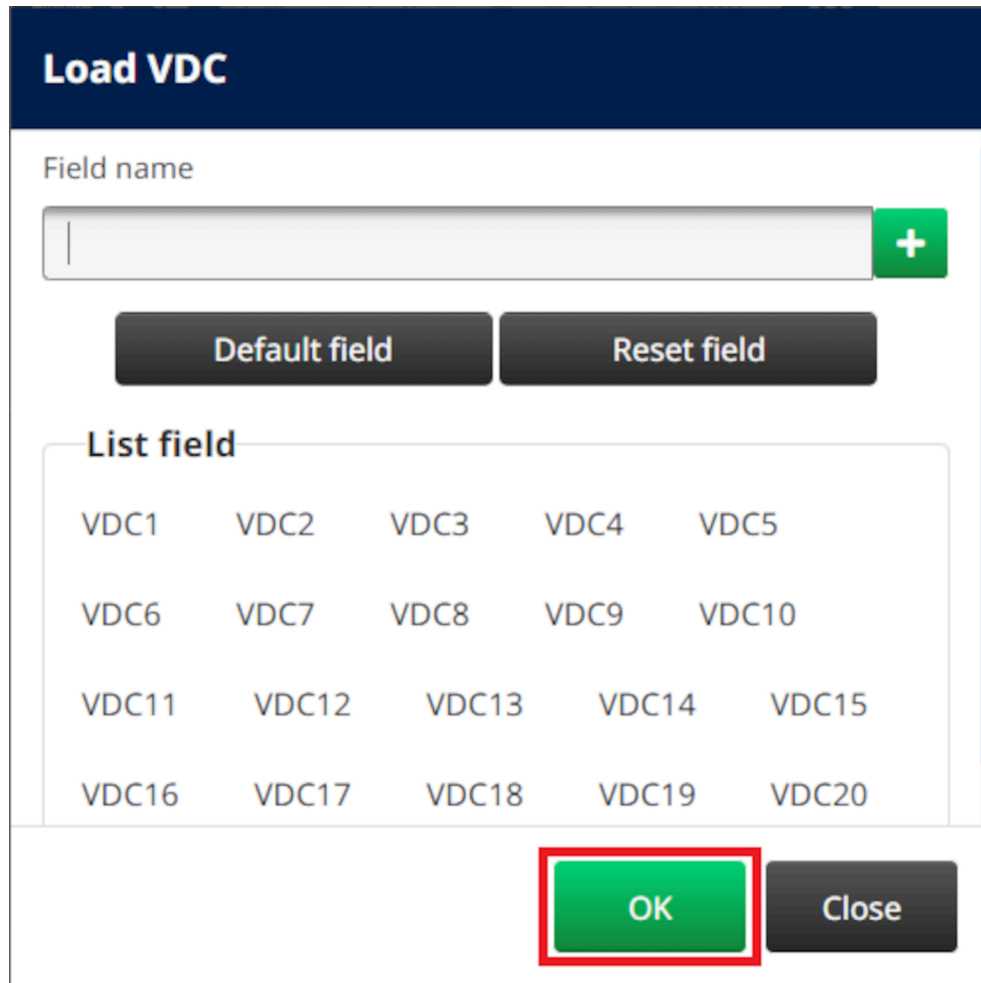

6. Select the *Select folder* icon:



7. Open the D:/ drive:



8. Find the folder that contains the image files, and select the green tick icon.

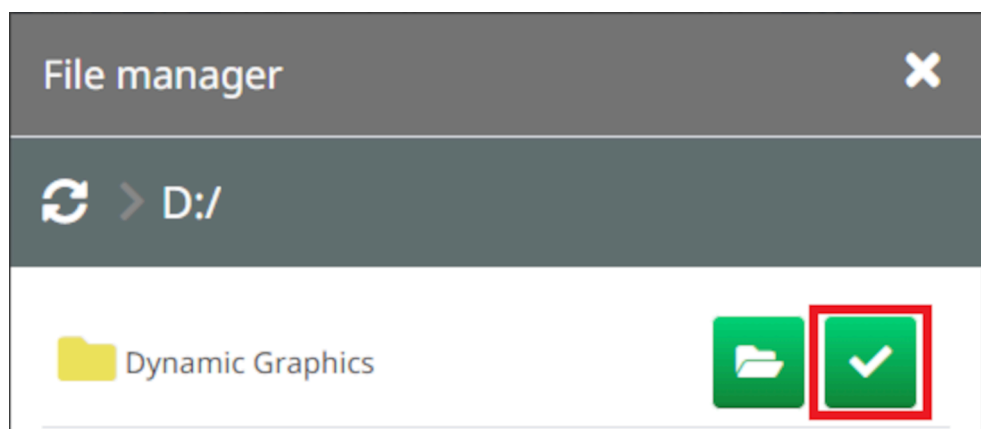

9. Select *OK*.

10. Drag the object to a suitable location in the template, or use the arrow icons to reposition the object:

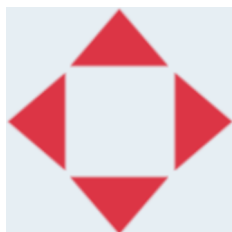

11. To adjust the object's properties, select the properties icon:

Note The properties icon is not used, if the web browser interface is being used.

12. In the *General* tab, use the settings listed below to change the object's general appearance:

Setting Name	Description
X (mm)	Set the horizontal position of the object in the template.
Y (mm)	Set the vertical position of the object in the template.
Width (mm)	Set the width of the object.
Height (mm)	Set the height of the object.
Scale mode	Set the scale mode of the object: <ul style="list-style-type: none"> <i>Scale</i> - The width and height of the object can be set independently. <i>Auto size</i> - The width and height of the object is controlled by the font size.
Angle	Rotate the object.
Lock	Lock the object to prevent it from being edited.
Visible	Make the object printable or not printable.

13. Select the *Graphics* tab, to change the VDC settings.

14. To populate the object with data, see [Populate the VDC Dynamic Graphics Object with Data on page 138](#).

Populate the VDC Dynamic Graphics Object with Data

Note If printing stops when VDC is in use, the printer's data buffer queue will be emptied. Data will need to be transmitted to the printer again.

To populate the VDC dynamic graphics object with data:

1. Select the *Save* icon, to save the label template: 

2. From the *Home* screen, select the *Folder* icon: 

3. Select the label template to load.

Note A preview of the template will be displayed.

4. Select *Open*.

5. Select the *Start* icon, to start printing: 

6. Transmit data (the file names of the images) from the external device to the printer.

7. A list of the selected images will now be shown at the bottom of the *Home* screen.

Add a Clocks Object

Note The system clock must be set up to print an accurate date/time value. See [Common on page 85](#).

To add a clocks object to the label template:



1. Select the *Object* icon:
2. Select *Clocks*.
3. Adjust the settings listed below:

Name	Description
Format	Set the date/time format. See Clocks Object Formats on page 142 .
Exp. Date	Add days to the object value For example, if the date is January 1st, and <i>Exp. Date</i> is set to 5, the date January 6th will be printed.
Roll mode	This setting lets the object continue to print yesterday's date for a period of time, or print tomorrow's date at an earlier time. For example, if this is set to <i>Back day</i> , and <i>Roll hours</i> is set to 5. At 04:00 am, January 2nd, the object will print 04:00 am, January 1st. Then, at 05:00 am, the object will advance to today's date and print 05:00 am, January 2nd. Or, if this is set to <i>Next day</i> , and <i>Roll hours</i> is set to 5. At 18:00 pm, January 2nd, the object will print 18:00 pm, January 2nd. Then, at 19:00 pm, the object will advance to tomorrow's date and print 19:00 pm, January 3rd. <ul style="list-style-type: none"> • None - Print the current time/date. • Back day - Use the <i>Roll hours</i> setting to continue printing yesterday's date for a period of time. • Next day - Use the <i>Roll hours</i> setting to begin printing tomorrow's date at an earlier time.
Roll hours	Note This setting is only valid, if <i>Roll mode</i> is set to <i>Back day</i> , or <i>Next day</i> . Set the number of hours that will be added to, or subtracted from the object's value.
Region	Set the date/time region.
Upper case	Set upper or lower case text for name of the month formats (MMM and MMMM).
Content	Display a preview of the object.

1. Select *OK*.

OPERATION

2. Drag the object to a suitable location in the template, or use the arrow icons to reposition the object:

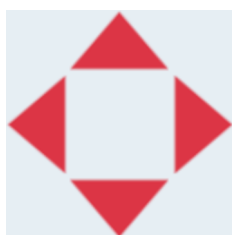

3. To change the object's appearance, select the properties icon:



Note The properties icon is not used, if the web browser interface is being used.

4. In the *General* tab, use the settings listed below to change the object's general appearance:

Setting Name	Description
X (mm)	Set the horizontal position of the object in the template.
Y (mm)	Set the vertical position of the object in the template.
Width (mm)	Set the width of the object.
Height (mm)	Set the height of the object.
Scale mode	Set the scale mode of the object: <ul style="list-style-type: none"> • Scale - The width and height of the object can be set independently. • Auto size - The width and height of the object is controlled by the font size.
Angle	Rotate the object.
Lock	Lock the object to prevent it from being edited.
Visible	Make the object printable or not printable.
Font family	Set the font type.
Size (pt)	Set the font size.
Style	Choose: <ul style="list-style-type: none"> • Bold • Italic • Underlined.
Text align	If the object has more than 1 line, set the alignment: <ul style="list-style-type: none"> • Left • Center • Right.
Remove blank line	Remove blank lines from the object.
Remove leading space	Remove leading spaces from the object.

OPERATION

5. In the *Clocks* tab, use the settings listed below to change the clocks object settings.

Name	Description
Format	Set the date/time format. See Clocks Object Formats on page 142 .
Exp. Date	Add days to the object value For example, if the date is January 1st, and <i>Exp. Date</i> is set to 5, the date January 6th will be printed.
Roll mode	This setting lets the object continue to print yesterday's date for a period of time, or print tomorrow's date at an earlier time. For example, if this is set to <i>Back day</i> , and <i>Roll hours</i> is set to 5. At 04:00 am, January 2nd, the object will print 04:00 am, January 1st. Then, at 05:00 am, the object will advance to today's date and print 05:00 am, January 2nd. Or, if this is set to <i>Next day</i> , and <i>Roll hours</i> is set to 5. At 18:00 pm, January 2nd, the object will print 18:00 pm, January 2nd. Then, at 19:00 pm, the object will advance to tomorrow's date and print 19:00 pm, January 3rd. <ul style="list-style-type: none"> • None - Print the current time/date. • Back day - Use the <i>Roll hours</i> setting to continue printing yesterday's date for a period of time. • Next day - Use the <i>Roll hours</i> setting to begin printing tomorrow's date at an earlier time.
Roll hours	Note This setting is only valid, if <i>Roll mode</i> is set to <i>Back day</i> , or <i>Next day</i> . Set the number of hours that will be added to, or subtracted from the object's value.
Region	Set the date/time region.
Upper case	Set upper or lower case text for name of the month formats (MMM and MMMM).
Content	Display a preview of the object.

Clocks Object Formats

The table below lists the valid date formats for datetime objects.

Date Format Character	Description
W	Week number of the year. Weeks start on Monday (1-53).
'N'	Day number of the week as a single numeric character (1-7).
'NN'	Day number of the week as 2 numeric characters (01-07).
'NO'	Day of the week as a single alpha character (A-G).
'ND'	Three letter abbreviated name of the day. Example: MON, TUE, WED etc.
'JJJ'	Day number of the year as a 3 numeric characters (001-365). Example: January 1st = 001, February 1st = 032 etc.
'y'	The year as a single digit. Example: 2025 = 5, 2030 = 0 etc.
'M'	The name of the month as a single alpha numeric character. Example: <ul style="list-style-type: none"> • January = 1 • February = 2 • March = 3 • April = 4 • May = 5 • June = 6 • July = 7 • August = 8 • September = 9 • October = O • November = N • December = D
dddd	The name of the day. Example: Monday, Tuesday Wednesday etc.
D	Day number of the month with no leading zero (1-31).
DD	Day number of the the month with leading zero (01-31).
MM	Month number of the year with leading zero (01-12).
MMM	The abbreviated name of the month. Example: Jan, Feb, Mar etc.

OPERATION

Date Format Character	Description
MMMM	The name of the month. Example: January, February, March etc.
YY	The year as a two digit number (00-99).
YYYY	The year as a four digit number.
h	Hour, 12 hour clock with no leading zero (1-12).
hh	Hour, 12 hour clock with leading zero (01-12).
H	Hour, 24 hour clock with no leading zero (0-23).
HH	Hour, 24 hour clock with leading zero (00-23).
mm	Minute (00-59).
ss	Second (00-59).
A	AM or PM.
, . / - : <SPACE>	Date separators.

Add a Shift Code Object

To add a shift code object to the label template:



1. Select the *Object* icon:
2. Select *Shift code*.
3. Adjust the settings listed below:

Name	Description
Code	Enter the name of each shift (0-5 characters). The shift name will be printed.
Time (24 hour)	Enter the start time of each shift. The time will not be printed.
Content	Display a preview of the object.

4. Select *OK*.
5. Drag the object to a suitable location in the template, or use the arrow icons to reposition the object:

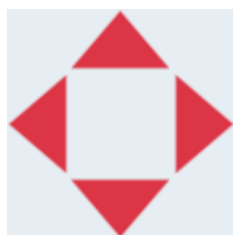

6. To change the object's appearance, select the properties icon:

Note The properties icon is not used, if the web browser interface is being used.

7. In the *General* tab, use the settings listed below to change the object's general appearance:

Setting Name	Description
X (mm)	Set the horizontal position of the object in the template.
Y (mm)	Set the vertical position of the object in the template.
Width (mm)	Set the width of the object.
Height (mm)	Set the height of the object.
Scale mode	Set the scale mode of the object: <ul style="list-style-type: none"> • Scale - The width and height of the object can be set independently. • Auto size - The width and height of the object is controlled by the font size.
Angle	Rotate the object.

OPERATION

Setting Name	Description
Lock	Lock the object to prevent it from being edited.
Visible	Make the object printable or not printable.
Font family	Set the font type.
Size (pt)	Set the font size.
Style	Choose: <ul style="list-style-type: none"> • Bold • Italic • Underlined.
Text align	If the object has more than 1 line, set the alignment: <ul style="list-style-type: none"> • Left • Center • Right.
Remove blank line	Remove blank lines from the object.
Remove leading space	Remove leading spaces from the object.

8. In the *Shift code* tab, use the settings listed below to change shift code settings.

Name	Description
Code	Enter the name of each shift (0-5 characters). The shift name will be printed.
Time (24 hour)	Enter the start time of each shift. The time will not be printed.
Content	Display a preview of the object.

Add a Line Object

To add a shift code object object to the label template:

1. Select the *Object* icon: 
2. Select *Line*.
3. Select *OK*.
4. Drag the object to a suitable location in the template, or use the arrow icons to reposition the object:

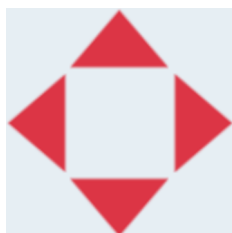

5. To adjust the object's properties, select the properties icon: 
- Note The properties icon is not used, if the web browser interface is being used.
6. In the *General* tab, use the settings listed below to change the object's general appearance:

Setting Name	Description
X (mm)	Set the horizontal position of the object in the template.
Y (mm)	Set the vertical position of the object in the template.
Width (mm)	Set the width of the object.
Height (mm)	Set the height of the object.
Scale mode	Set the scale mode of the object: <ul style="list-style-type: none"> • <i>Scale</i> - The width and height of the object can be set independently. • <i>Auto size</i> - The width and height of the object is controlled by the font size.
Angle	Rotate the object.
Lock	Lock the object to prevent it from being edited.
Visible	Make the object printable or not printable.

Add a Boxlot Object

A boxlot object is a dual counter that is used to count the box and products in the box.

To add a boxlot object to the label template:



1. Select the *Object* icon:
2. Select *Boxlot*.
3. Change the settings listed below:

Name	Description
Main counter	Select the counter that will be printed first as the main counter. <ul style="list-style-type: none"> • Counter 1 • Counter 2
Separate	Enter the character that will be printed in between the 2 counters to separate them.

4. Select *Counter 1*.
5. Change the settings listed below for *Counter 1*.

Name	Description
Start value	Set the counter object's start value.
End value	Set the counter object's end value.
Step value	Set the counter object's increment/step value.
Repeat time	Set the number of times each counter value will be repeated.
Padding character	Set the number of padding characters (Range: 1 to 10)
Step	Set the counting direction: <ul style="list-style-type: none"> • Up • Down.

6. Select *Counter 2*.
7. Change the settings listed below for *Counter 2*.

Name	Description
Start value	Set the counter object's start value.
End value	Set the counter object's end value.
Step value	Set the counter object's increment/step value.
Repeat time	Set the number of times each counter value will be repeated.
Padding character	Set the number of padding characters (Range: 1 to 10)

OPERATION

Name	Description
Step	Set the counting direction: <ul style="list-style-type: none"> • Up • Down.

8. Select *OK*.
9. Drag the object to a suitable location in the template, or use the arrow icons to reposition the object:

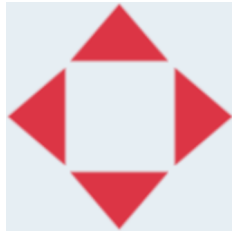

10. To change the object's appearance, select the properties icon:



Note The properties icon is not used, if the web browser interface is being used.

11. In the *General* tab, use the settings listed below to change the object's general appearance:

Setting Name	Description
X (mm)	Set the horizontal position of the object in the template.
Y (mm)	Set the vertical position of the object in the template.
Width (mm)	Set the width of the object.
Height (mm)	Set the height of the object.
Scale mode	Set the scale mode of the object: <ul style="list-style-type: none"> • Scale - The width and height of the object can be set independently. • Auto size - The width and height of the object is controlled by the font size.
Angle	Rotate the object.
Lock	Lock the object to prevent it from being edited.
Visible	Make the object printable or not printable.
Font family	Set the font type.
Size (pt)	Set the font size.
Style	Choose: <ul style="list-style-type: none"> • Bold • Italic • Underlined.

OPERATION

Setting Name	Description
Text align	If the object has more than 1 line, set the alignment: <ul style="list-style-type: none"> • Left • Center • Right.
Remove blank line	Remove blank lines from the object.
Remove leading space	Remove leading spaces from the object.

12. In the *Boxlot* tab, use the settings to change boxlot object settings.

SAVE LABEL TEMPLATE

To save the label template, select the *Save* icon:



SAVE LABEL TEMPLATE WITH DIFFERENT NAME

To save the label template with a different name:



1. Select the *Save as* icon:
2. Enter a different name for the label template.
3. Select *Save*.

EDIT OBJECT PROPERTIES

To edit a label object's properties:

1. Open the label template in the label template designer.
2. Select the object.
3. Select the properties icon: 
4. Different tabs for different property settings are available, depending on the object type.

DELETE LABEL TEMPLATE

Note A label template cannot be deleted, if it is loaded to print.

To delete a label template:





1. From the home screen, select the *Folder* icon: 
2. Select the template.

Note A preview of the template will be displayed.

3. Select the *Delete* icon: 

IMPORT LABEL TEMPLATE

To import a label template from a USB memory device:

1. Put the label template file onto a USB memory device.
2. Connect the USB memory device to the printer.
3. From the home screen, select the *Design* icon: 
4. Select the *More* icon: 
5. Select *Import template*.
6. Select the *Select file* icon: 
7. Open the D:/ drive: 
8. Select the label template.
9. Select *Next*.
10. Select *OK*.

EXPORT LABEL TEMPLATE

To export a label template to a USB memory device:

1. Connect a USB memory device to the printer.

2. From the home screen, select the *Design* icon:



3. Select the *More* icon:



4. Select *Export template*.

5. Select the label template to export

6. Select *Next*.

7. Select the *Select file* icon:



8. Select the D:/ drive, or open a folder on the D:/ drive:



9. Select *OK*.

LOG

The G50i records a log of all user actions. Logs older than 6 months are automatically deleted.





Log information includes:

- Date/time that the action was recorded
- The user who was logged in
- The type/category of action
- A description of the action.

To view the log:

1. From the *Home* screen, select the *Log* icon: 
2. Adjust the dates in the top right corner, to set the viewing date range.
3. Use the icons listed below, to filter the log by action type.

Note More than 1 filter can be applied at the same time.

	Filter "error" actions.
	Filter "warning" events.
	Filter "information" events.
	Filter "stop print" events.
	Filter "start print" events.

Export Log

The log can be exported from the printer to a USB memory device. The export is a .zip file that contains .txt files.

To export the log:

1. Connect the USB memory device to the printer.
2. From the *Home* screen, select the *Log* icon: 
3. Adjust the dates in the top right corner, to choose a date range to export.
4. Select *Export*.
5. If required, change the file name of the export. The default file name is:
log_00000000_99999999.zip
 - 00000000 is the first date selected in the export range
 - 99999999 is the last date selected in the export range.
1. Choose a folder on the USB memory device to save the export to.
2. Select *OK*.

STATISTIC COUNTERS

The printer has 2 statistic counters that record the number of prints made.

1 counter can be reset by the user at any time. The other counter cannot be reset.

To view the statistic counters:

1. From the *Home* screen, select the *Log* icon: 
2. Select the *Statistic* tab.
3. In the *Parameters* section of the screen, view the 2 counters.
4. To change the names of the counters, select the counter name and enter a new name.
5. To reset 1 of the counters, select *Reset*.

The history of the counter values can also be viewed.

To view the history of the counter values:









1. From the *Home* screen, select the *Log* icon: 
2. Select the *Statistic* tab.
3. Use the *Filter* options to select a date range.
4. In the *Production total print count* section of the screen, view the history of the counter values.

PART 5 MAINTENANCE & TROUBLESHOOTING

ERROR DESCRIPTION

Error	Description
Stop print (Normal event)	"Stop" has been selected on the user interface. Printing will be stopped. No light is on.
Invalid Cartridge	The ink cartridge is not a valid/genuine ink cartridge.
No Cartridge	No ink cartridge is installed.
Ink Low	The ink level in the cartridge is below 5 ml.
Ink Out	The ink level in the cartridge is below 0.4 ml.
Speed Limit	The speed measured by the encoder is too fast. The printer cannot print at this speed. See, Printing Speed Table.
VDC/Real Time Printing Speed Overload	<p>If real time printing is enabled, after the product detect sensor is triggered, the label template will immediately be encoded and sent from the controller to the printhead.</p> <p>If the total time to encode and send the label data to the printhead is longer than the time it takes for the product/print surface to move from the product detect sensor to the printhead, the label may not print. If this event occurs, printing will stop and this error will be displayed.</p> <p>To solution to this error, is to slow down the production line, or physically move the product detect sensor further away from the printhead.</p>

PRINT QUALITY FAULTS

Problem	Example	Action
Print face too far away from the substrate		Lower the printhead until the print quality is acceptable
Print face touching the substrate		Raise the printhead until the print quality is acceptable
Print face at an angle		Ensure the rows of print nozzles are parallel with the leading edge of the substrate
Print nozzles parallel with the movement of the substrate		Ensure the printnozzles are perpendicular to the product movement
Print face nozzles have become blocked		Wipe print face or perform a micro purge. If the nozzles do not unblock replace the ink cartridge
Print becomes blurred over the top or bottom of the text		Print nozzles are perpendicular to product movement. However, the print face is not parallel to the substrate
The encoder is slipping or internal speed set on the printer does not match the actual line speed		Check the encoder installation or the speed settings on the printer
Print too faint		Increase horizontal or vertical DPI
Print too dark/too much ink on substrate or ink consumption too high		Decrease horizontal or vertical DPI

UPDATE SOFTWARE/FIRMWARE

To update the printer's software/firmware:

1. Put the update file into the top level (root folder) of a USB memory device.
2. Stop printing.
3. Connect the USB memory device to the printer.

4. From the *Home* screen, select the *Update* icon:



5. Select the *Select file* icon:



6. Open the D:/ drive:



7. Select the update file, to complete "Step 1".

Notes 1. Update files have an .io extension.

2. If the update file cannot be seen, select the *Refresh* icon:



8. Select *Next*, to upload the file to the printer and complete "Step 2".

Note Do not remove the USB memory device, until the file is uploaded to the printer.

9. Select *Next*, to verify the update file and complete "Step 3".



10. After the file is verified, select *Next* to install the update file and complete "Step 4".

Notes 1. Do not turn off the printer, disconnect the printer from electrical power, or change the screen until the update file has installed.

2. After the update file has successfully installed, the printer will automatically restart.

11. After the printer has restarted, the printer is ready for use.

REPLACE INK CARTRIDGE

WARNING Hazardous Chemicals. Risk of eye and skin damage.	
	<p>Wear protective equipment such as gloves and glasses when near the printer.</p> <p>Contact with chemicals can cause skin or eye damage. Refer to Safety Data Sheet.</p>
CAUTION Fragile Electrical Contacts. Risk of Equipment Damage.	
	<p>Do not force the cartridge into the printhead.</p> <p>Be careful when inserting the cartridge. Forcing the cartridge against the electrical contacts can break the contacts on the printhead circuit board.</p>

- Notes
1. Change the ink cartridge promptly to avoid poor printing.
 2. If printing stops when VDC is in use, the printer's data buffer queue will be emptied. Data will need to be transmitted to the printer again.

Required tools and equipment: Ethanol cleaning wipes, and lint free cloth/tissue.

To replace the ink cartridge:

1. Stop printing, select the *Stop* icon: 
2. Open the latch and remove the ink cartridge.

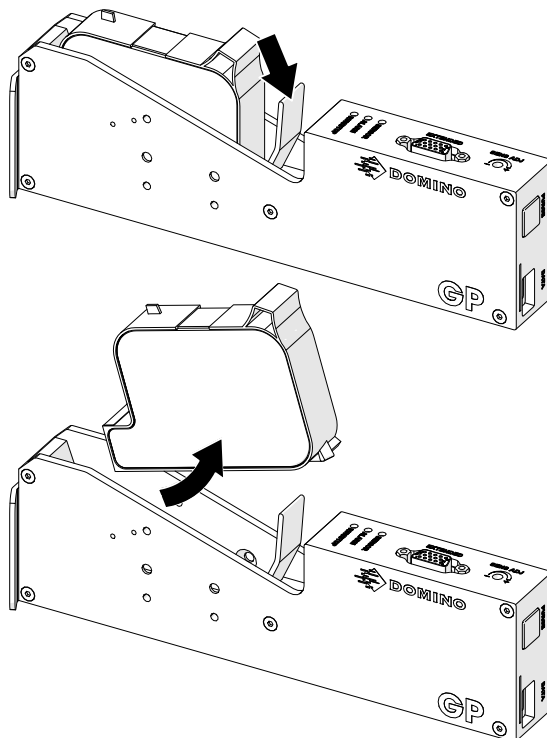

3. Remove the protective cover from the new ink cartridge.
4. If the cartridge is new, clean the electrical contacts with an ethanol wipe, to remove corrosion protection.

Note Cleaning wipe part number: EPT039697

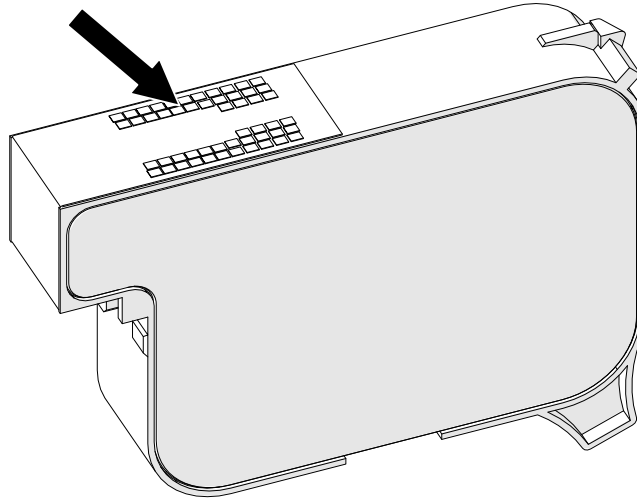

5. Use a new/clean lint-free cloth to wipe the ink cartridge nozzles at a 45° angle.

Note The 45° angle stops debris from one nozzle contaminating the next nozzle.

CAUTION	Sensitive Equipment. Risk of Equipment Damage.
	<p>Do not use an ethanol wipe or any other chemical to clean the cartridge nozzles.</p> <p>Use a new/clean lint-free cloth. If chemicals are used to clean the cartridge, the nozzles may be damaged.</p>

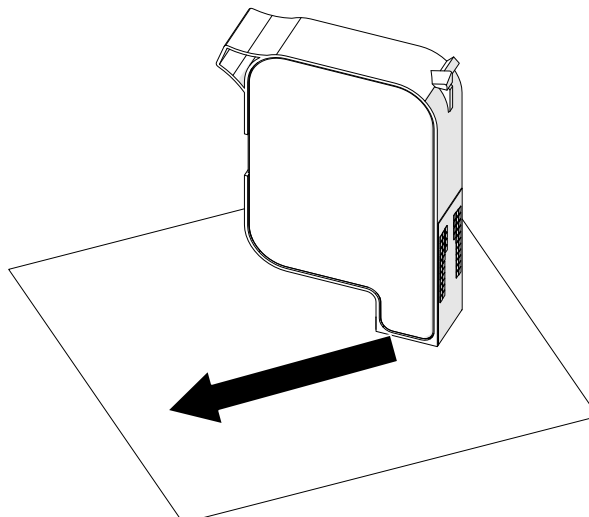

6. Insert the ink cartridge into the printhead and close the printhead latch.

CAUTION Fragile Electrical Contacts. Risk of Equipment Damage.	
	<p>Do not force the cartridge into the printhead.</p> <p>Be careful when inserting the cartridge. Forcing the cartridge against the electrical contacts can break the contacts on the printhead circuit board.</p>

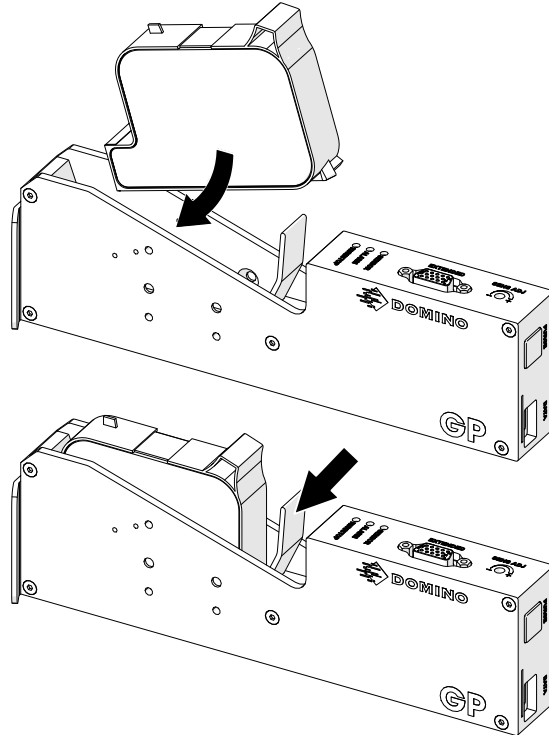

7. Obey local waste disposal regulations, to dispose of the used ink cartridge.

PURGE BLOCKED CARTRIDGE NOZZLES

WARNING

Hazardous Chemicals. Risk of eye and skin damage.



Wear protective equipment such as gloves and glasses when near the printer.

Contact with chemicals can cause skin or eye damage.
Refer to Safety Data Sheet.



If the cartridge nozzles become blocked, a purge can be used to eject very small quantities of ink out of the cartridge nozzles. Ink may mark items that are close to the printhead.

There are 2 different ways to do a purge:

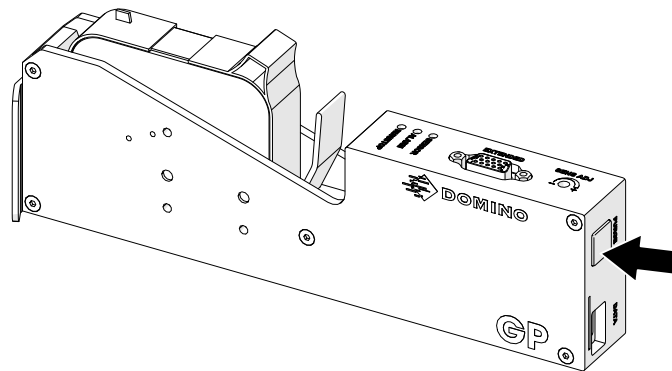
1. From the *Home* screen, select the *Purge* icon: 
2. Or, press the *Purge* button on the printhead:



CLEAN THE CARTRIDGE NOZZLES

WARNING Hazardous Chemicals. Risk of eye and skin damage.	
	<p>Wear protective equipment such as gloves and glasses when near the printer.</p> <p>Contact with chemicals can cause skin or eye damage. Refer to Safety Data Sheet.</p>
WARNING Flammable Material. Risk of Fire.	
	<p>Do not use flammable substances to clean the product.</p> <p>Using flammable substances may cause a fire. Only use a dry lint-free cloth.</p>
CAUTION Fragile Electrical Contacts. Risk of Equipment Damage.	
	<p>Do not force the cartridge into the printhead.</p> <p>Be careful when inserting the cartridge. Forcing the cartridge against the electrical contacts can break the contacts on the printhead circuit board.</p>

Note If printing stops when VDC is in use, the printer's data buffer queue will be emptied. Data will need to be transmitted to the printer again.

To clean the ink cartridge nozzles:

1. Stop printing, select the *Stop* icon: 

- Open the latch and remove the ink cartridge.

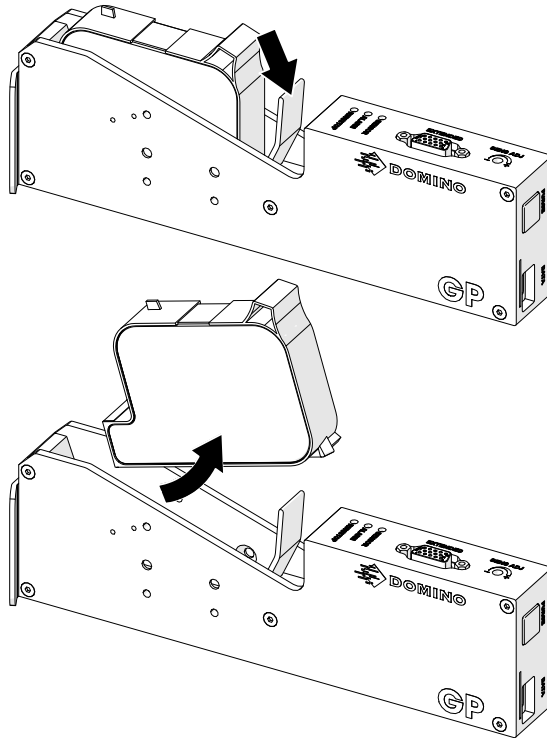

- Use a new clean dry lint-free cloth to wipe the ink cartridge nozzles at a 45° angle.

Note The 45° angle stops debris from one nozzle contaminating the next nozzle.

CAUTION Sensitive Equipment. Risk of Equipment Damage.	
	<p>Do not use an ethanol wipe or any other chemical to clean the cartridge nozzles.</p> <p>Use a new/clean lint-free cloth. If chemicals are used to clean the cartridge, the nozzles may be damaged.</p>

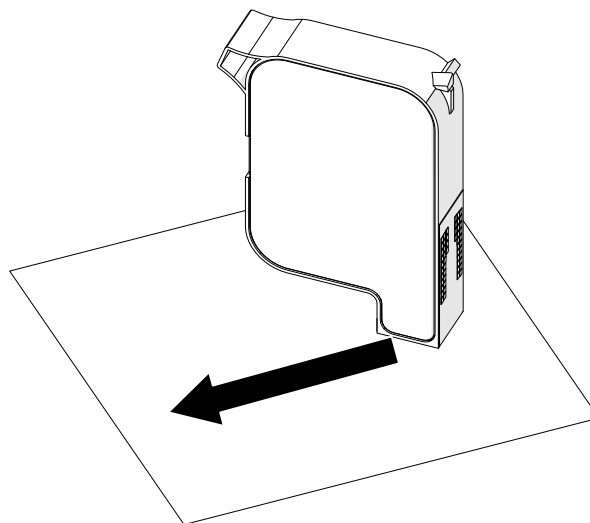





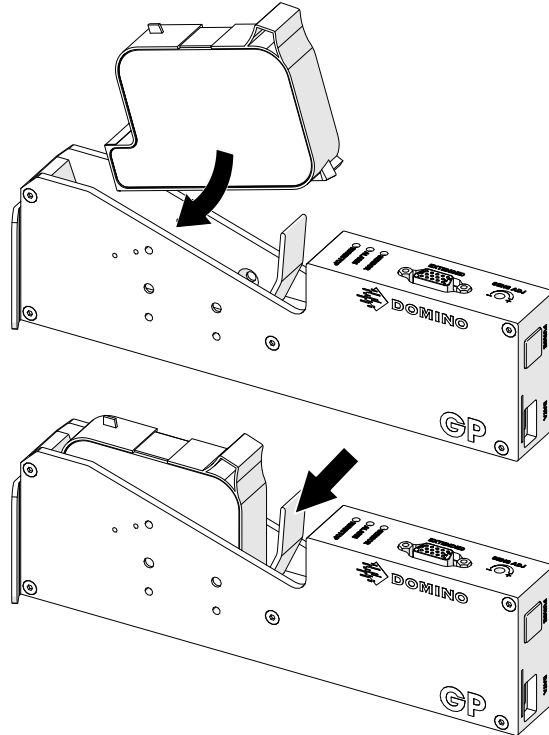

4. Insert the ink cartridge into the printhead and close the printhead latch.

CAUTION Fragile Electrical Contacts. Risk of Equipment Damage.	
	<p>Do not force the cartridge into the printhead.</p> <p>Be careful when inserting the cartridge. Forcing the cartridge against the electrical contacts can break the contacts on the printhead circuit board.</p>



CLEAN THE PRINTHEAD

WARNING		Hazardous Chemicals. Risk of eye and skin damage.
  	<p>Wear protective equipment such as gloves and glasses when near the printer.</p> <p>Contact with chemicals can cause skin or eye damage. Refer to Safety Data Sheet.</p>	
WARNING		Flammable Material. Risk of Fire.
 	<p>Do not use flammable substances to clean the product.</p> <p>Using flammable substances may cause a fire. Only use a dry lint free cloth, or a lint free cloth moistened with water.</p>	
CAUTION		Electricity. Risk of damage to equipment.
	<p>Liquids can short circuit electrical connections and cause damage. Do not let liquids make contact with any electrical connections.</p>	
CAUTION		Low Ingress Protection. Risk of damage to equipment.
	<p>The printheads have no ingress protection against liquids. Spraying the equipment with a water jet may cause damage. Do not spray the equipment with a water jet.</p>	

Note If printing stops when VDC is in use, the printer's data buffer queue will be emptied. Data will need to be transmitted to the printer again.

To clean the printhead:

1. From the home screen, select the *Standby* icon  and select *Shut down*. Or, press and hold the *Standby* button shown below for 2 seconds.

Note Selecting the *Standby* icon or pressing the *Standby* button does not disconnect the printer from the electrical power supply.

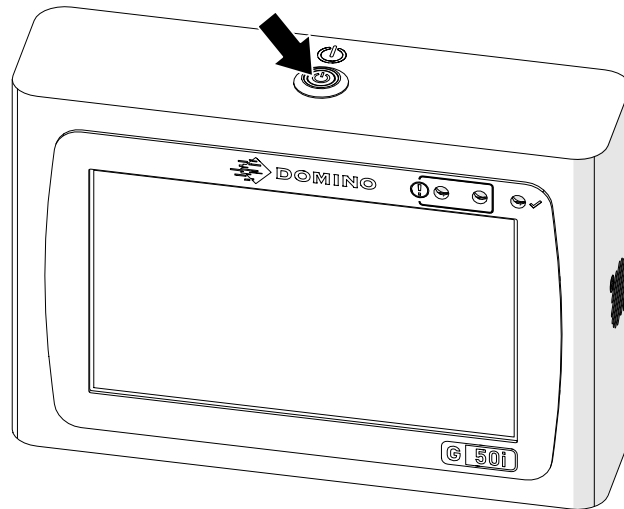

2. Disconnect the controller from the electrical power supply.
3. Open the latch and remove the ink cartridge.

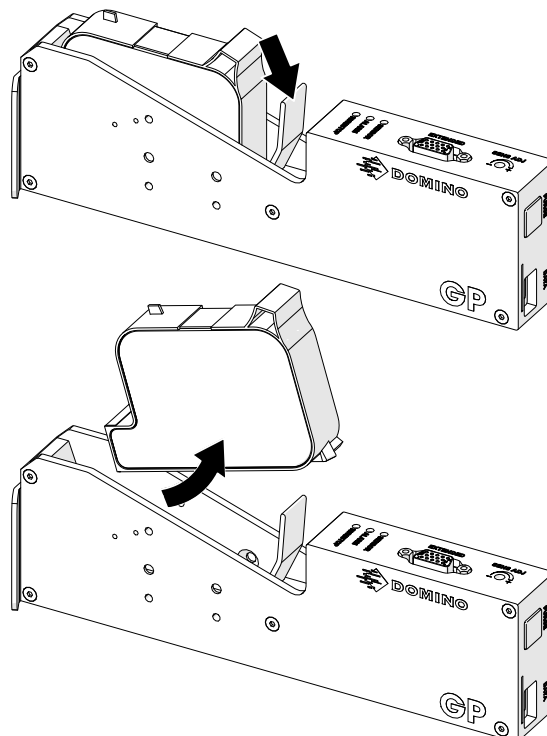





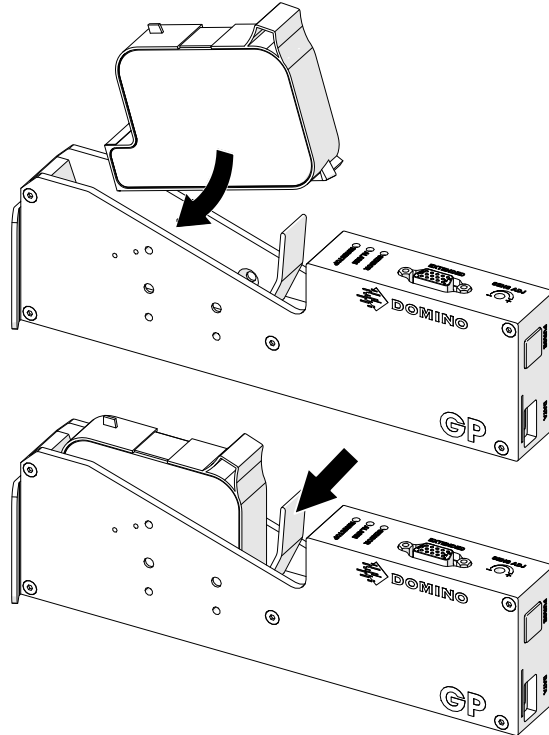

4. Use a clean lint free cloth moistened with water, to wipe the printhead clean.
5. Make sure that the printhead and electrical connectors are dry, before re-inserting the ink cartridge, re-connecting the electrical power supply and turning the printer back on.

6. Insert the ink cartridge into the printhead and close the printhead latch.

CAUTION Fragile Electrical Contacts. Risk of Equipment Damage.	
	<p>Do not force the cartridge into the printhead.</p> <p>Be careful when inserting the cartridge. Forcing the cartridge against the electrical contacts can break the contacts on the printhead circuit board.</p>



CLEAN THE CONTROLLER

WARNING		Hazardous Chemicals. Risk of eye and skin damage.
  	<p>Wear protective equipment such as gloves and glasses when near the printer.</p> <p>Contact with chemicals can cause skin or eye damage. Refer to Safety Data Sheet.</p>	
WARNING		Flammable Material. Risk of Fire.
 	<p>Do not use flammable substances to clean the product.</p> <p>Using flammable substances may cause a fire. Only use a dry lint free cloth, or a lint free cloth moistened with water.</p>	
CAUTION		Electricity. Risk of damage to equipment.
	<p>Liquids can short circuit electrical connections and cause damage. Do not let liquids make contact with any electrical connections.</p>	
CAUTION		Low Ingress Protection. Risk of damage to equipment.
	<p>The controller has no ingress protection against liquids. Spraying the controller with a water jet may cause damage. Do not spray the controller with a water jet.</p>	

Note If printing stops when VDC is in use, the printer's data buffer queue will be emptied. Data will need to be transmitted to the printer again.

To clean the controller:

1. From the home screen, select the *Standby* icon  and select *Shut down*. Or, press and hold the *Standby* button shown below for 2 seconds.

Note Selecting the *Standby* icon or pressing the *Standby* button does not disconnect the printer from the electrical power supply.

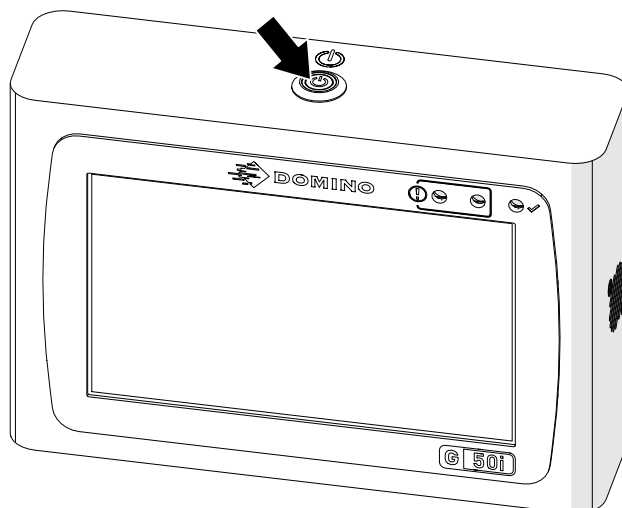

2. Disconnect the controller from the electrical power supply.
3. Use a clean lint free cloth moistened with water, to wipe the controller clean.
4. Make sure that the printhead and electrical connectors on the controller are dry, before connecting the controller to the electrical power supply and turning the printer back on.



Domino G-Series Product Manual

Domino Printing Sciences plc has a policy of continuous product improvement, the Company therefore reserves the right to modify the specification contained within this document without notice.

© Domino Printing Sciences plc 2023. All rights reserved.



For additional documentation, including other available languages, either scan the QR code, or go to <https://mydomino.domino-printing.com>

Domino UK Limited

Trafalgar Way
Bar Hill
Cambridge CB23 8TU
United Kingdom

Tel: +44 (0)1954 782551
Fax: +44 (0)1954 782874
Email: enquiries@domino-uk.com

Domino Amjet Inc.

1290 Lakeside Drive
Gurnee IL.60031
U.S.A.

Tel: +1 847 244 2501
Fax: +1 847 244 1421
Email: solutions@domino-na.com